

1 3/4" BORE STAINLESS STEEL CYLINDER



SSN-28-□-□

Single Acting



Mount: Stud **Standard Stroke Lengths:** 1/2", 1", 1-1/2", 2", 3", 4"
Type: Non-Rotating Rod **Spring Compressed:** 24 lbs. **Spring At Rest:** 11 lbs.
Options: M, V, S, N **Maximum Stroke:** 20"

Bumpers are standard
 For M option add 0.125
 For S option add 0.562

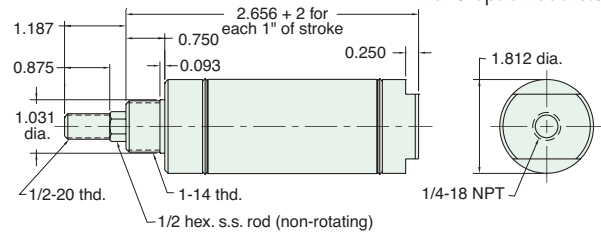

Nut included, but not shown on drawing

SSR-28-□-□

Single Acting



Mount: Stud **Standard Stroke Lengths:** 1/2", 1", 1-1/2", 2", 3", 4"
Type: Rotating Rod **Spring Compressed:** 24 lbs. **Spring At Rest:** 11 lbs.
Options: M, V, S, N, W **Maximum Stroke:** 20"

Bumpers are standard
 For M option add 0.1255
 For S option add 0.562

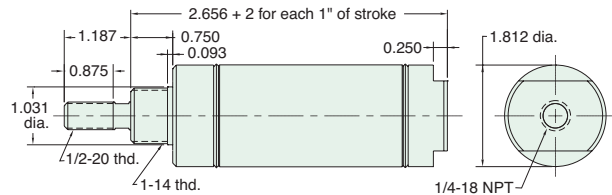

Nut included, but not shown on drawing

USN-28-□-□

Single Acting



Mount: Universal **Standard Stroke Lengths:** 1/2", 1", 1-1/2", 2", 3", 4"
Type: Non-Rotating Rod **Spring Compressed:** 24 lbs. **Spring At Rest:** 11 lbs.
Options: M, V, P6, N **Maximum Stroke:** 20"

Bumpers are standard. For M option add 0.125

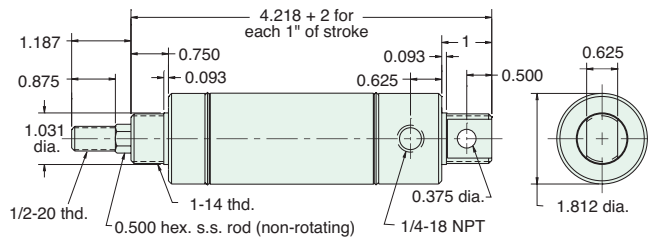

Furnished without nut(s). See Chart on Page 50.

USR-28-□-□

Single Acting



Mount: Universal **Standard Stroke Lengths:** 1/2", 1", 1-1/2", 2", 3", 4"
Type: Rotating Rod **Spring Compressed:** 24 lbs. **Spring At Rest:** 11 lbs.
Options: M, V, P6, N, W **Maximum Stroke:** 20"

Bumpers are standard. For M option add 0.125

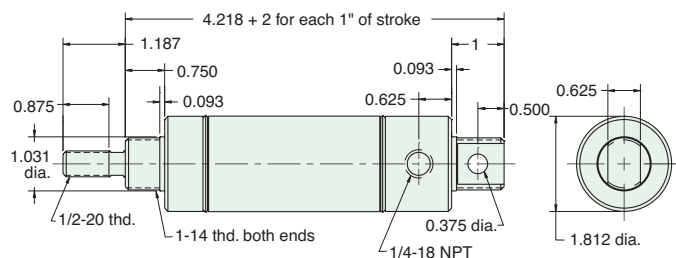

Furnished without nut(s). See Chart on Page 50.



1 3/4" BORE STAINLESS STEEL CYLINDER

SDR-28-□-□

Double Acting



Mount: Stud **Standard Stroke Lengths:** 1/2", 1", 1-1/2", 2", 3", 4", 5", 6"
Type: Rotating Rod **Maximum Stroke:** 39"
Options: C, F, R, M, W, V, P6, P7, P8, S, N

Bumpers are standard

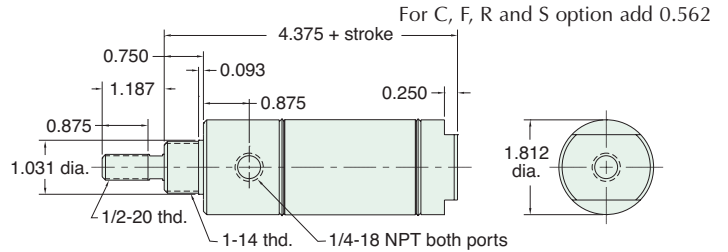

Nut included, but not shown on drawing
For C, F, & R options use side ported rear head

UDR-28-□-□

Double Acting



Mount: Universal **Standard Stroke Lengths:** 1/2", 1", 1-1/2", 2", 3", 4", 6", 8", 10", 12"
Type: Rotating Rod **Maximum Stroke:** 37"
Options: C, F, R, M, W, V, P2, P3, P4, P5, P6, P7, P8, N

Bumpers are standard

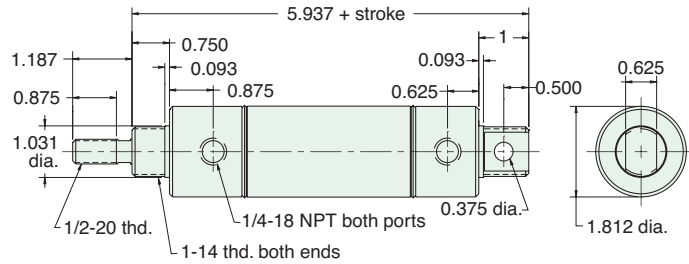

Furnished without nut(s). See Chart on Page 50.

SDD-28-□-□

Double Acting



Mount: Stud **Standard Stroke Lengths:** 1", 2", 3", 4", 5", 6", 8", 10", 12"
Type: Double Rod **Maximum Stroke:** 18"
Options: C, F, M, W, V, P6, P7, P8, N

Bumpers are standard

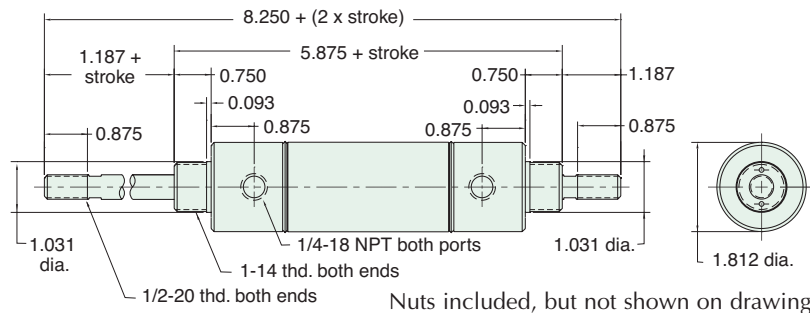

SRR-28-□-□

Reverse Acting



Mount: Stud **Standard Stroke Lengths:** 1/2", 1", 1-1/2", 2", 3", 4"
Type: Rotating Rod **Spring Compressed:** 24 lbs. **Spring At Rest:** 11 lbs.
Options: M, W, V, N **Maximum Stroke:** 13"

Bumpers are standard

For M option add 0.125

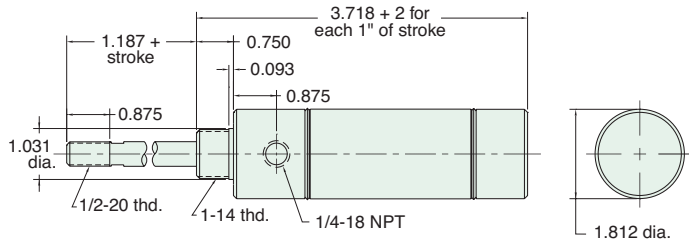

Nut included, but not shown on drawing

1 3/4" BORE STAINLESS STEEL CYLINDER



URR-28-□-□

Reverse Acting

Mount: Universal **Standard Stroke Lengths:** 1/2", 1", 1-1/2", 2", 3", 4"
Type: Rotating Rod **Spring Compressed:** 24 lbs. **Spring At Rest:** 11 lbs.
Options: M, W, V, P2, N **Maximum Stroke:** 12" **Bumpers are standard**
 For M option add 0.125

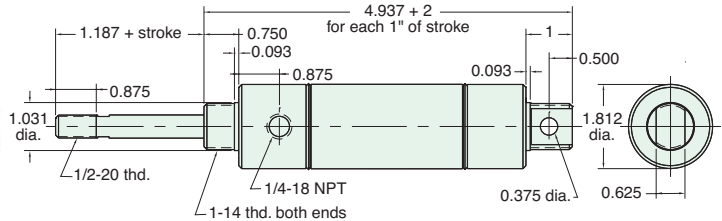

Furnished without nut(s). See Chart on Page 50.

Dual Double Stacked Cylinder Press

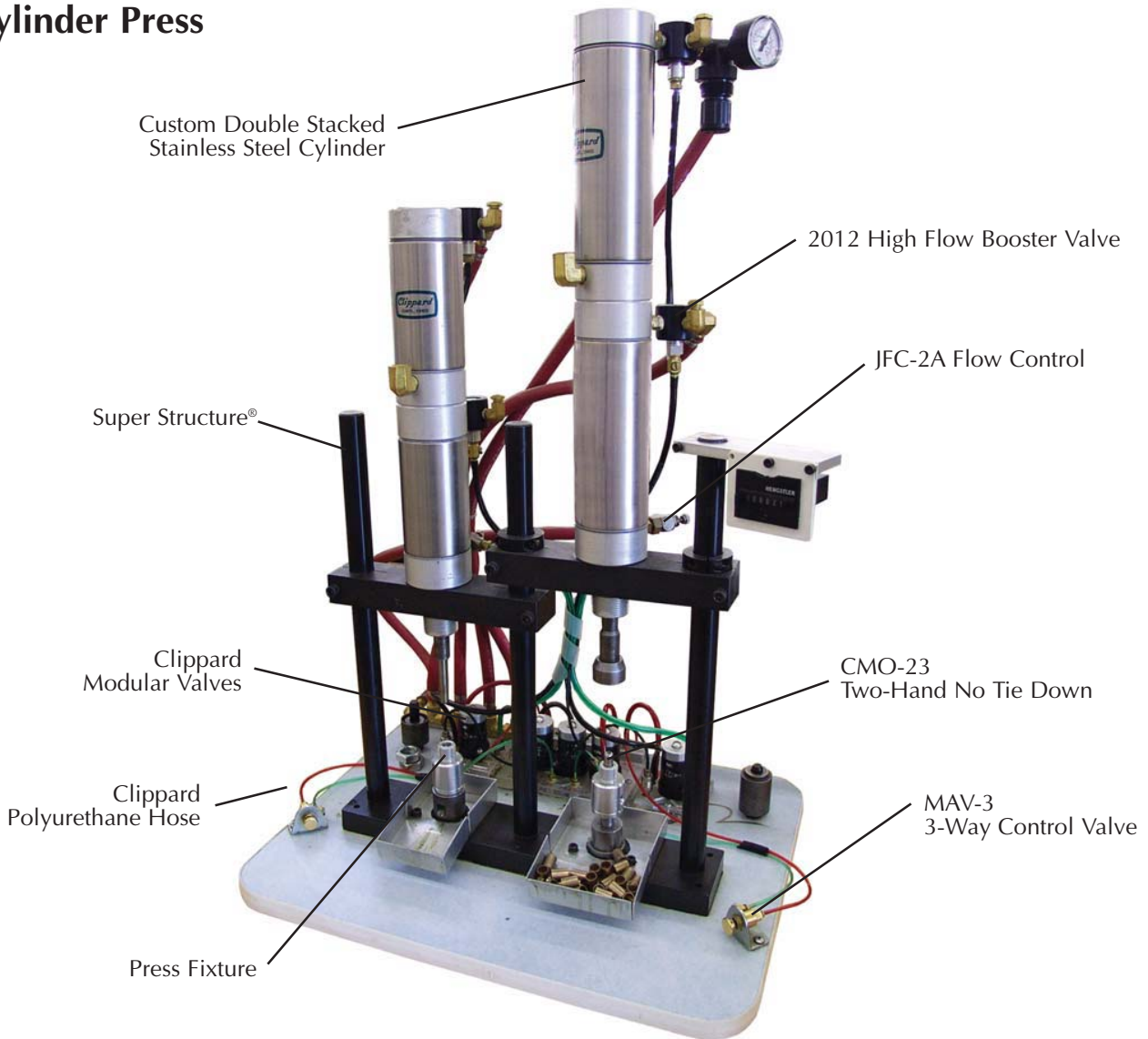



1 3/4" BORE ACCESSORIES



MOUNTING NUTS

Stud Nut

Part Number	Across Flats	Nut Thickness	Nut (Thread)
N16-14	1 1/2"	35/64"	1-14

Rod Nut

Part Number	Across Flats	Nut Thickness	Nut (Thread)
N07-20	11/16"	1/4"	7/16-20

CB-2495

Clevis Bracket
Material: Steel, bright zinc plated

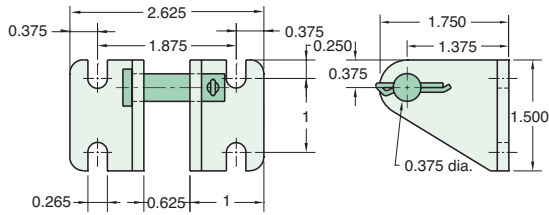

RK-2899

Replaceable Rod Seal
Material: Aluminum body

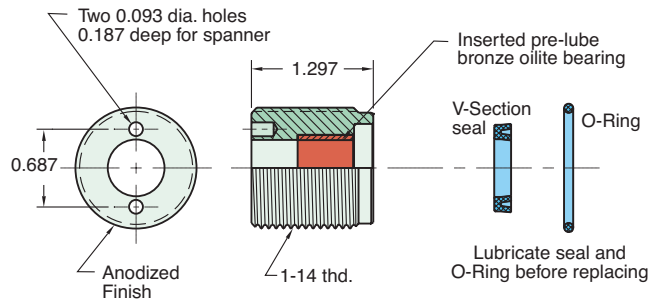

RC-3281

Rod Clevis
Material: Steel, electroless nickel plate

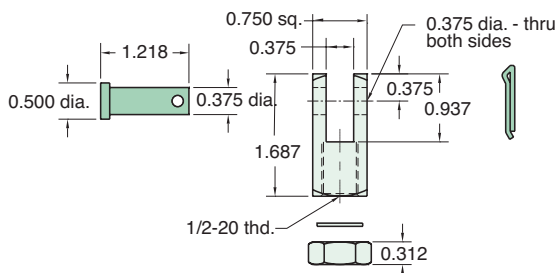

RE-3285

Rod End
Material: Steel, bright zinc plated body

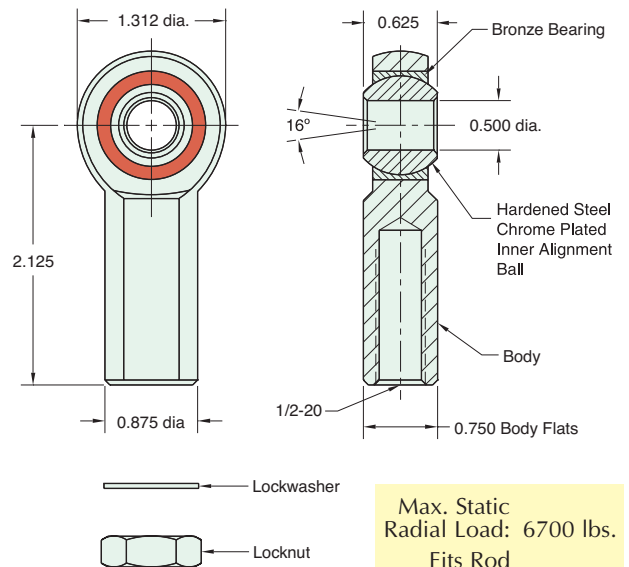

Max. Static Radial Load: 6700 lbs.
Fits Rod Thread Size: 1/2-20

FB-2891

Foot Bracket
Material: Steel, bright zinc plated

