

3" BORE STAINLESS STEEL CYLINDER



SDR-48-□-□

Double Acting



Mount: Stud **Standard Stroke Lengths:** 1", 2", 3", 4", 5", 6"
Type: Rotating Rod **Maximum Stroke:** 34"
Options: M, W, V, P6, P7, P8, S, N

Bumpers are standard
 No additional length for bumpers
 For S option add 0.437

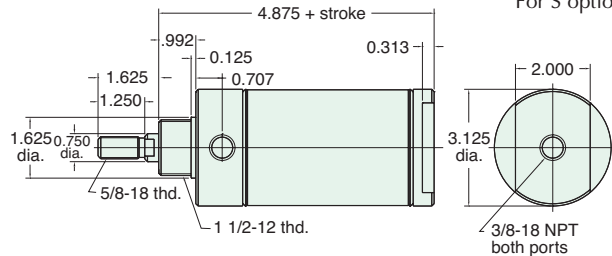

Nut included, but not shown on drawing

UDR-48-□-□

Double Acting



Mount: Universal **Standard Stroke Lengths:** 1", 2", 3", 4", 5", 6", 7", 8", 10", 12"
Type: Rotating Rod **Maximum Stroke:** 32"
Options: M, W, V, P2, P3, P4, P5, P6, P7, P8, N

Bumpers are standard
 No additional length for bumpers

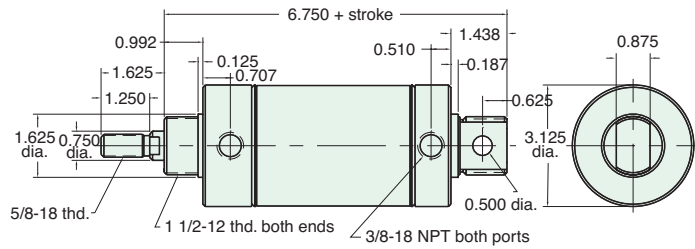

Furnished without nut(s). See Chart on Page 58.

SDD-48-□-□

Double Acting



Mount: Stud **Standard Stroke Lengths:** 1", 2", 3", 4", 5", 6", 8", 10", 12"
Type: Double Rod **Maximum Stroke:** 15"
Options: M, W, V, P6, P7, P8, N

Bumpers are standard
 No additional length for bumpers

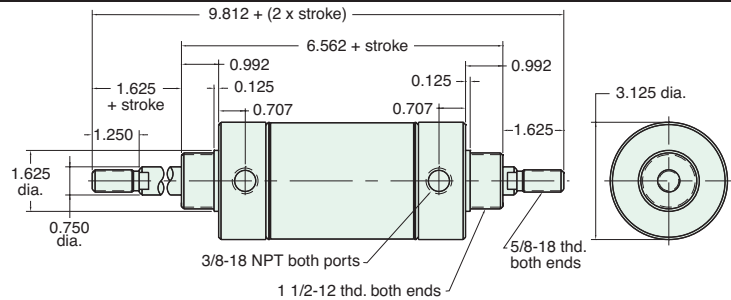

Nuts included, but not shown on drawing

Did you know...

Minimatic®, Maximatic®,
 Minimetric®, Fluidamp®,
 Octoport®, Air-2-Electric® and Air
 Force One® are all Clippard's
 registered trademarks.





3" BORE ACCESSORIES



MOUNTING NUTS

Stud Nut

Part Number	Across Flats	Nut Thickness	Nut (Thread)
N24-12	2 1/4"	1/2"	1 1/2-12

Rod Nut

Part Number	Across Flats	Nut Thickness	Nut (Thread)
N08-20	3/4"	5/16"	1/2-20

CB-4895

Clevis Bracket
Material: Steel, bright zinc plated

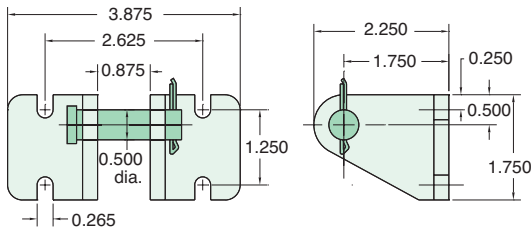

RK-4899

Replaceable Rod Seal
Material: aluminum body

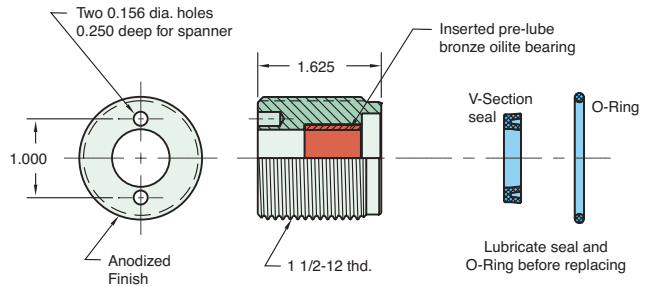

RC-4881

Rod Clevis
Material: Steel, electroless nickel plate

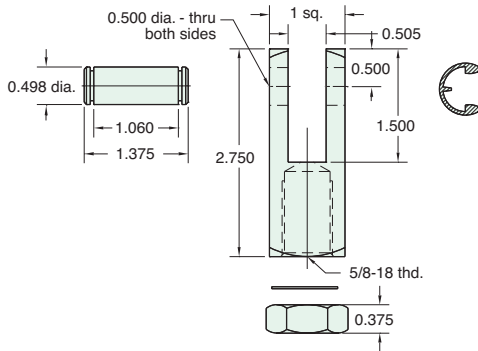

RE-4885

Rod End
Material: Steel, bright zinc plated body

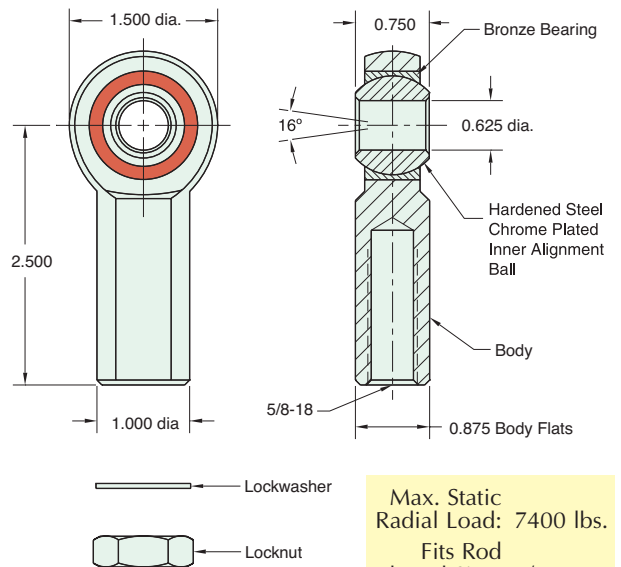

Max. Static Radial Load: 7400 lbs.
Fits Rod Thread Size: 5/8-18

FB-4891

Foot Bracket
Material: Steel, bright zinc plated

