

NEW! 9/16" BORE STAINLESS STEEL CYLINDER



USN-09-□-□

Single Acting



Mount: Universal **Standard Stroke Lengths:** 1/2", 1", 1-1/2", 2", 3", 4"
Type: Non-Rotating Rod **Spring Compressed:** 4 lbs. **Spring At Rest:** 1.7 lbs.
Options: B, V, P6, N, M, MB **Maximum Stroke:** 23" For B option add 0.063
 For M or MB option add 0.125

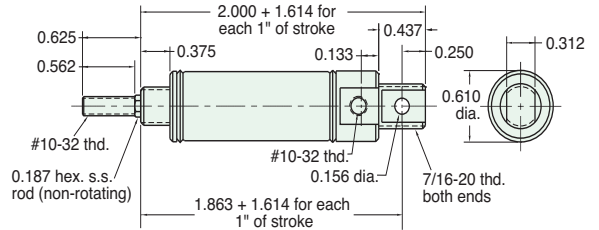

Furnished without nut(s). See Chart on Page 17.

USR-09-□-□

Single Acting



Mount: Universal **Standard Stroke Lengths:** 1/2", 1", 1-1/2", 2", 3", 4"
Type: Rotating Rod **Spring Compressed:** 4 lbs. **Spring At Rest:** 1.7 lbs.
Options: B, V, P6, N, M, MB **Maximum Stroke:** 23" For B option add 0.063
 For M or MB option add 0.125

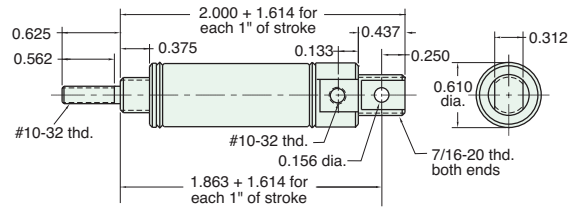

Furnished without nut(s). See Chart on Page 17.

SSN-09-□-□

Single Acting



Mount: Stud **Standard Stroke Lengths:** 1/2", 1", 1-1/2", 2", 3", 4"
Type: Non-Rotating Rod **Spring Compressed:** 4 lbs. **Spring At Rest:** 1.7 lbs.
Options: B, V, N, M, MB **Maximum Stroke:** 23" For B option add 0.063
 For M or MB option add 0.125

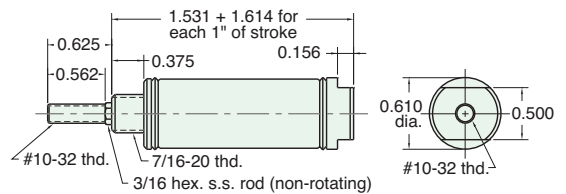

Nut included, but not shown on drawing

SSR-09-□-□

Single Acting



Mount: Stud **Standard Stroke Lengths:** 1/2", 1", 1-1/2", 2", 3", 4"
Type: Rotating Rod **Spring Compressed:** 4 lbs. **Spring At Rest:** 1.7 lbs.
Options: B, V, N, M, MB **Maximum Stroke:** 23" For B option add 0.063
 For M or MB option add 0.125

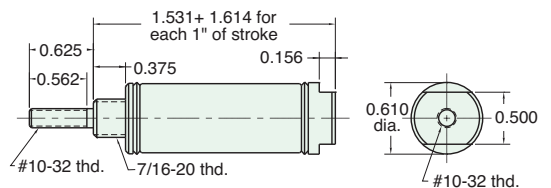

Nut included, but not shown on drawing



NEW! 9/16" BORE STAINLESS STEEL CYLINDER

SDD-09-□-□

Double Acting

Mount: Stud **Standard Stroke Lengths:** 1/2", 1", 1-1/2", 2", 3", 4"
Type: Double Rod **Maximum Stroke:** 20"
Options: B, V, P6, P7, P8, N, M, MB For B option add 0.125

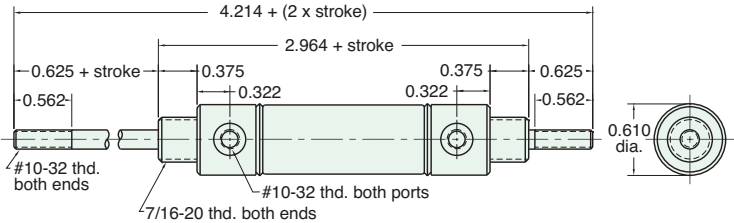

Nuts included, but not shown on drawing

SRR-09-□-□

Reverse Acting

Mount: Stud **Standard Stroke Lengths:** 1/2", 1", 1-1/2", 2", 3", 4"
Type: Rotating Rod **Spring Compressed:** 4 lbs. **Spring At Rest:** 1.7 lbs.
Options: B, V, N, M, MB **Maximum Stroke:** 15" For B option add 0.563
For M or MB option add 0.125

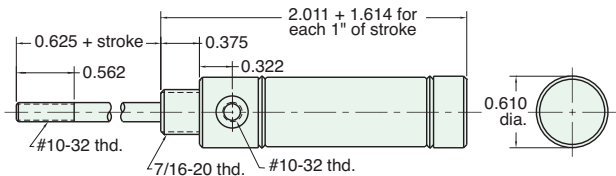

Nut included, but not shown on drawing

URR-09-□-□

Reverse Acting

Mount: Universal **Standard Stroke Lengths:** 1/2", 1", 1-1/2", 2", 3", 4"
Type: Rotating Rod **Spring Compressed:** 4 lbs. **Spring At Rest:** 1.7 lbs.
Options: B, V, P2, N, M, MB **Maximum Stroke:** 14" For B option add 0.063
For M or MB option add 0.125

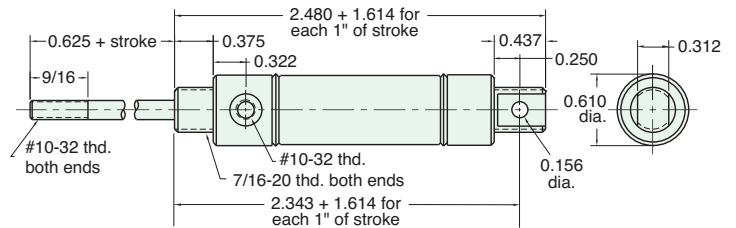

Furnished without nut(s). See Chart on Page 17.

SDR-09-□-□

Double Acting

Mount: Stud **Standard Stroke Lengths:** 1/2", 1", 1-1/2", 2", 3", 4"
Type: Rotating Rod **Maximum Stroke:** 43"
Options: B, V, P6, P7, P8, N, M, MB For B option add 0.125

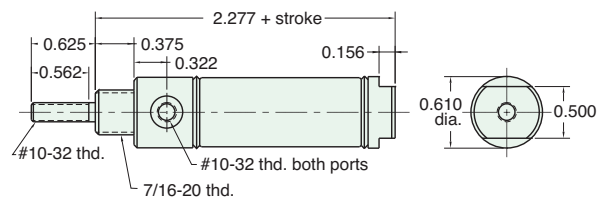

Nut included, but not shown on drawing

NEW! 9/16" BORE STAINLESS STEEL CYLINDER



UDR-09-□-□

Double Acting



Mount: Universal **Standard Stroke Lengths:** 1/2", 1", 1-1/2", 2", 3", 4"
Type: Rotating Rod **Maximum Stroke:** 43"
Options: B, V, P2, P3, P4, P5, P6, P7, P8, N, M, MB

For B option add 0.125

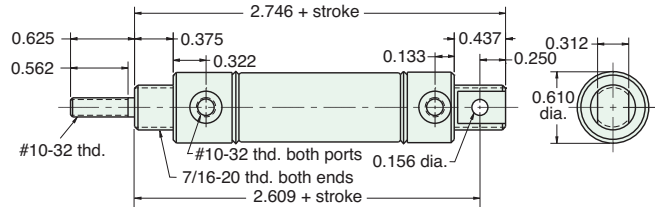

Furnished without nut(s). See Chart below.



MOUNTING NUTS

Stud Nut

Part Number	Across Flats	Nut Thickness	Nut (Thread)
N07-20	11/16"	1/4"	7/16-20

Rod Nut

Part Number	Across Flats	Nut Thickness	Nut (Thread)
N03-32	3/8"	1/8"	#10-32

CB-0895

Clevis Bracket
Material: Steel, bright zinc plated

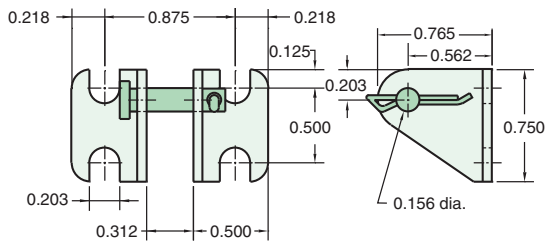

RE-0885

Rod End
Material: Steel, bright zinc plated body

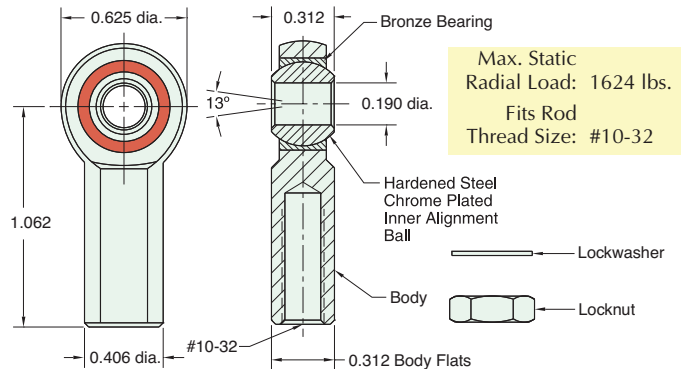

RC-0881

Rod Clevis
Material: Steel, electroless nickel plate

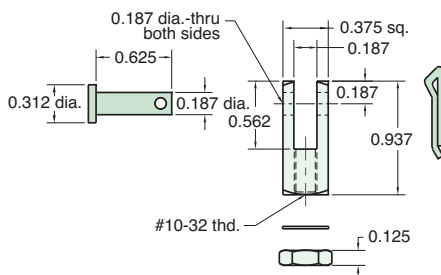

FB-0892

Foot Bracket
Material: Steel, bright zinc plated

