

Accessoires température

Raccords, doigts de gant

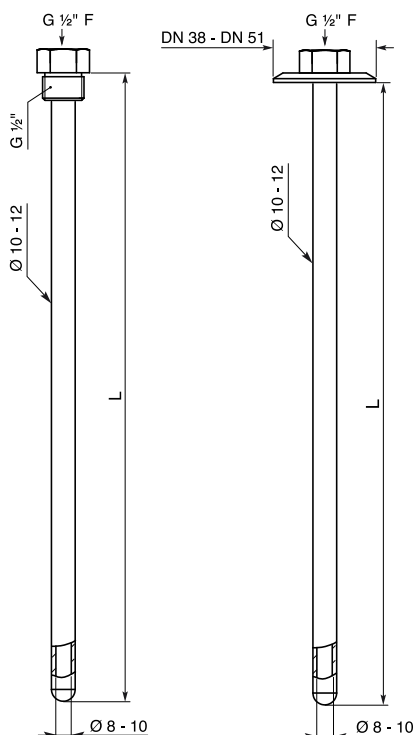

Raccords coulissants

Acier inox 316 L

Ø sonde	Filetage Gaz	Code	Filetage NPT	Code
3 mm	G 1/8"	220 202	NPT 1/8"	220 202NPT
6 mm	G 1/4"	220 200	NPT 1/4"	220 200NPT
6 mm	G 1/2"	220 205	NPT 1/2"	220 205NPT
8 mm	G 1/2"	218 305	NPT 1/2"	218 305NPT
8 mm	G 3/4"	218 306	NPT 3/4"	218 306NPT

Doigts de gant pour sonde Ø 6 mm

Mécano-soudé - acier inox 316 L - G 1/2" femelle

L [mm]	Filetage	Clamp	
		DN 38-Férule 50,5 mm	DN 51-Férule 64 mm
	Code	Code	Code
50	220 215	220 215C38	220 215C51
100	220 220	220 220C38	220 220C51
150	220 225	220 225C38	220 225C51
200	220 226		
250	220 229		
300	220 230		
400	220 235		

Doigts de gant pour sondes Ø 8 mm

Mécano-soudé - acier inox 316 L - G 1/2" femelle

L [mm]	Filetage	Doigt de gant clamp	
		DN 38 (1,5") - Férule 50.5mm	DN 51 (2") - Férule 64 mm
	Code	Code	Code
50	218 363	218 363C38	218 363C51
100	218 365	218 365C38	218 365C51
160	218 366	218 366C38	218 366C51
250	218 367	218 367C38	218 367C51

Brides

Inox pour Ø 6 ou 8 mm – Ovale en fonte pour Ø 21,3, Ø 22 ou Ø 33 mm

Bride en inox		Brides en fonte	
Ø sonde	Code	Ø sonde	Code
6 mm	229 950	13,5 mm	229 900
8 mm	229 960	15 mm	229 910
		21,3 mm	229 920

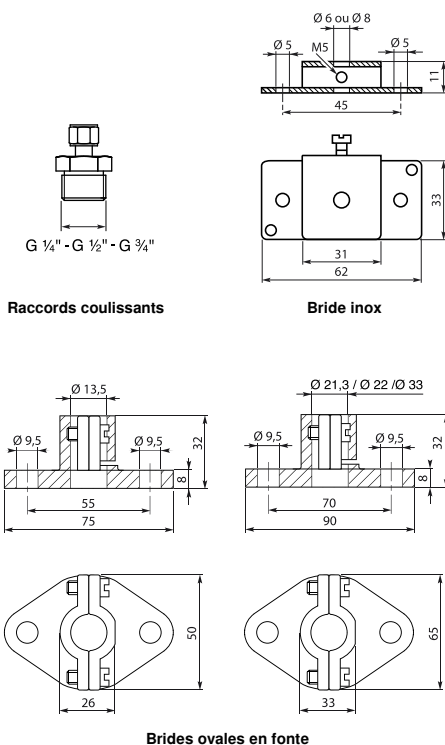

Raccords coulissants

Bride inox

Brides ovales en fonte



Z.I. Nord Torcy · Allée du Plateau, bât. n°2 · 77200 TORCY
 Tél. +33 (0)1 60 37 45 00 Site www.citec.fr
 Fax +33 (0)1 64 80 45 18 Mél. citec@citec.fr

Accessoires température
 Raccords, doigts de gant

03-12-2019

D-635.10-FR-AA

TE

635-10/1