

Assembly Order No.	Rubber Material	F1	F2	Clamp Ring	Body Material	Max Restricted Pressure (psig/bar)	Max Unrestricted Pressure (psig/bar)
WP1-358-7000	Neoprene	10-24 UNC	10-32 UNF	Stainless Steel	Aluminum	20 / 1.5	10 / 0.75
WP1-358-7004	Silicone	10-24 UNC	10-32 UNF	Stainless Steel	Aluminum	15 / 1	7.5 / 0.5
WP1-M58-5001	Neoprene	M5	M5	Stainless Steel	Aluminum	20 / 1.5	10 / 0.75
WP1-M58-5005	Silicone	M5	M5	Stainless Steel	Aluminum	15 / 1	7.5 / 0.5

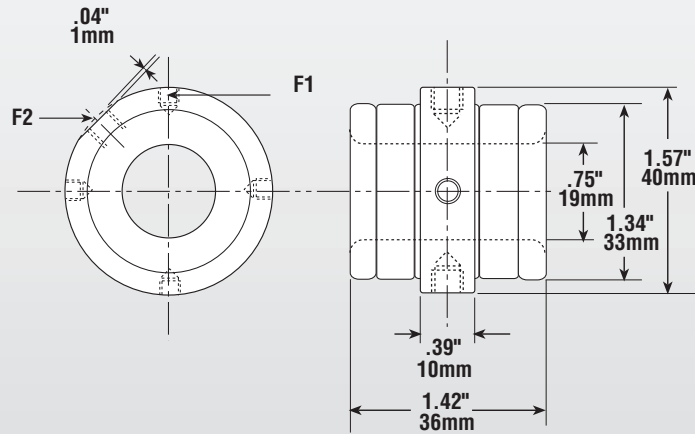

IMPERIAL

FORCE CURVES

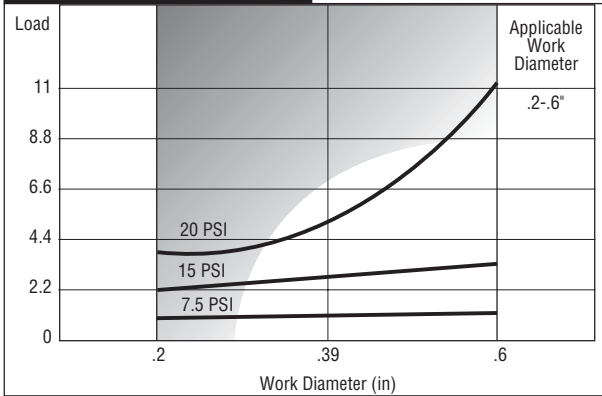

PRESSURE VS INFLATED DIAMETER

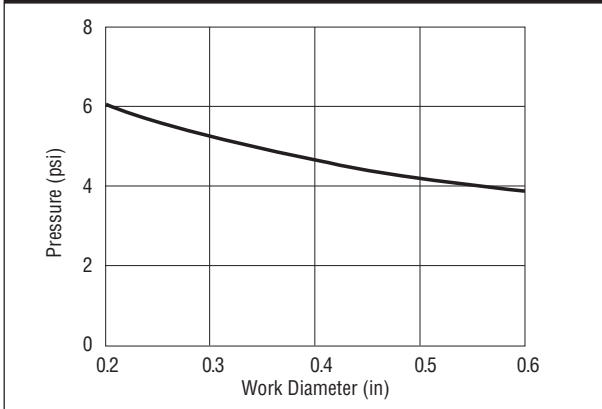

METRIC

FORCE CURVES

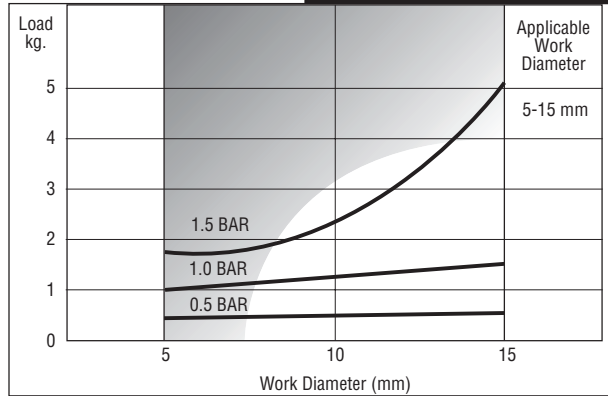

PRESSURE VS INFLATED DIAMETER

