

Assembly Order No.	Rubber Material	F1	F2	Clamp Ring	Body Material	Max Restricted Pressure (psig/bar)	Max Unrestricted Pressure (psig/bar)
WP1-358-7002	Neoprene	10-24 UNC	1/8 - 27 NPT	Stainless Steel	Aluminum	20 / 1.5	10 / 0.75
WP1-358-7006	Silicone	10-24 UNC	1/8 - 27 NPT	Stainless Steel	Aluminum	15 / 1	7.5 / 0.5
WP1-M58-5003	Neoprene	M5	M6	Stainless Steel	Aluminum	20 / 1.5	10 / 0.75
WP1-M58-5007	Silicone	M5	M6	Stainless Steel	Aluminum	15 / 1	7.5 / 0.5

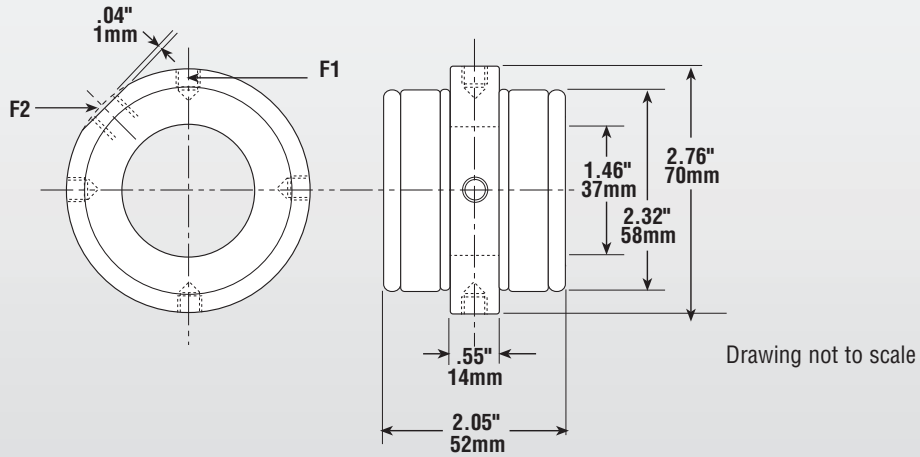

## IMPERIAL

## METRIC

### FORCE CURVES

### FORCE CURVES

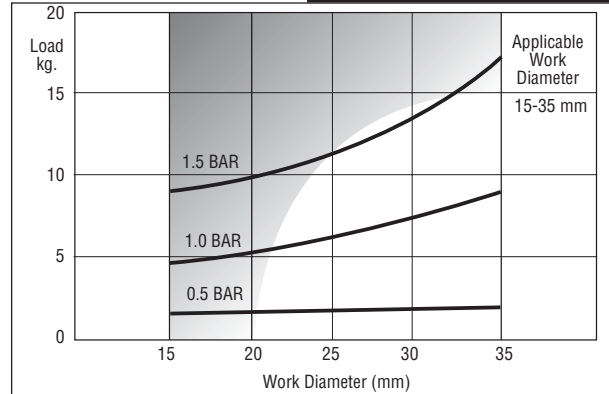
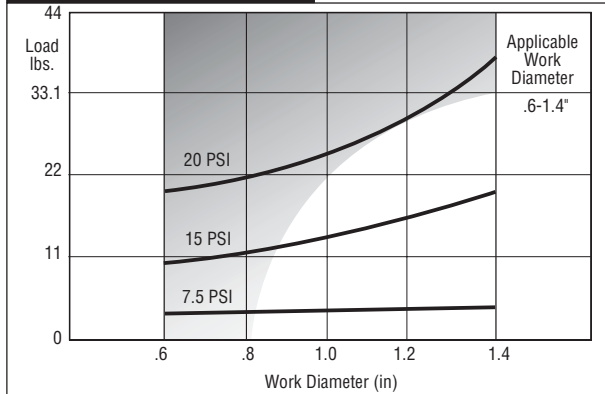

### PRESSURE VS INFLATED DIAMETER

### PRESSURE VS INFLATED DIAMETER

