

Assembly Order No.	Rubber Material	F1	F2	F3	Clamp Ring	Body Material	Max Restricted Pressure (psig/bar)	Max Unrestricted Pressure (psig/bar)
WP1-M58-0011	Neoprene	PT 1/8	M6	N/A	Stainless Steel	Aluminum	70 / 5	35 / 2.4
WP1-M58-0028	Silicone	PT 1/8	M6	N/A	Stainless Steel	Aluminum	25 / 1.8	12 / 0.8
WP1-358-2006	Neoprene	1/8-27 NPT	1/8-27 NPT	N/A	Stainless Steel	Aluminum	70 / 5	35 / 2.4
WP1-358-2014	Silicone	1/8-27 NPT	1/8-27 NPT	N/A	Stainless Steel	Aluminum	25 / 1.8	12 / 0.8

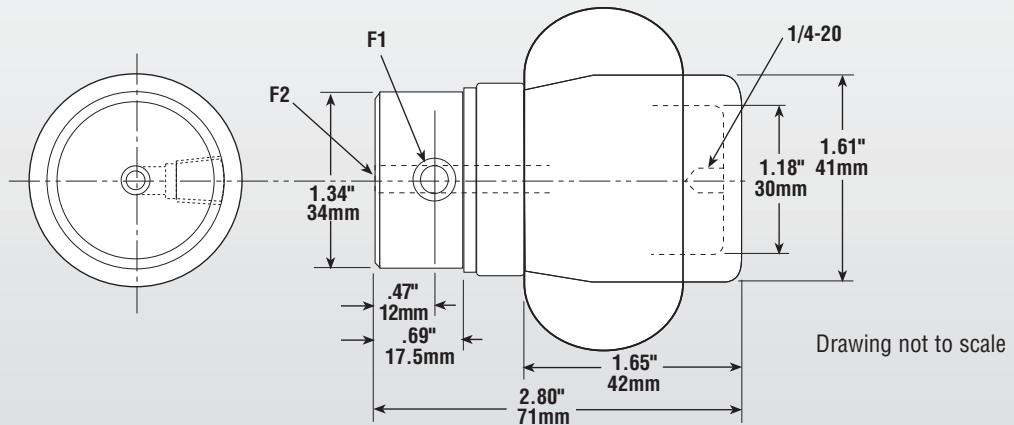

**IMPERIAL**

**FORCE CURVES**

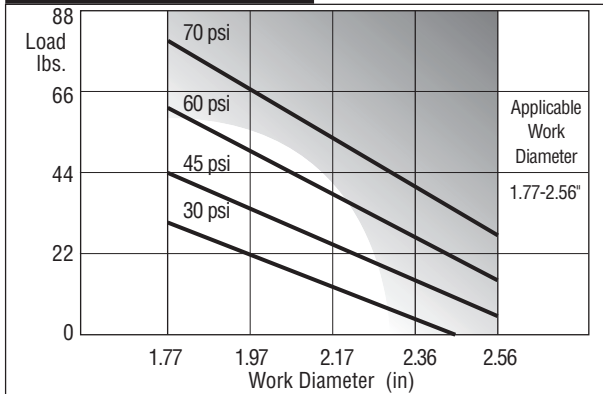

**PRESSURE VS INFLATED DIAMETER**

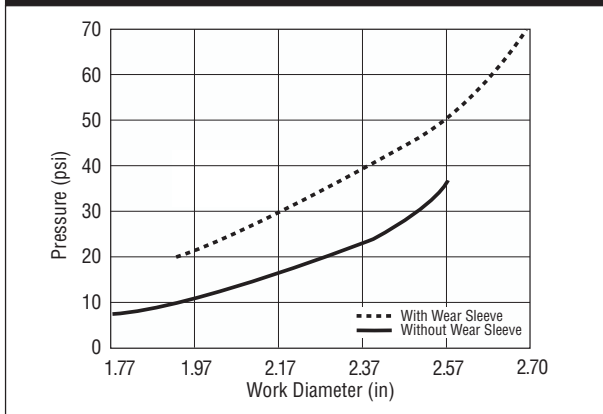

**METRIC**

**FORCE CURVES**

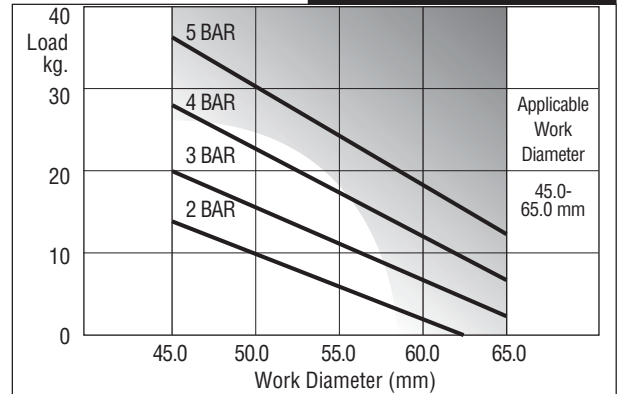

**PRESSURE VS INFLATED DIAMETER**

