

Description		Assembly Order No.
Style 119	Ribbed neck aluminum bead rings (equal spacing), 1 7/8 bolts, nuts, washers	WO1-358-7478
Two Ply	Rubber bellows only	WO1-358-0119
Bellows	Rolled Plate Assembly, 1/2 blind nuts, 3/4 NPT	WO1-358-7477
Assembly weight .....		13.2 lbs.
Force to collapse to minimum height (@ 0 PSIG).....		17 lbs.

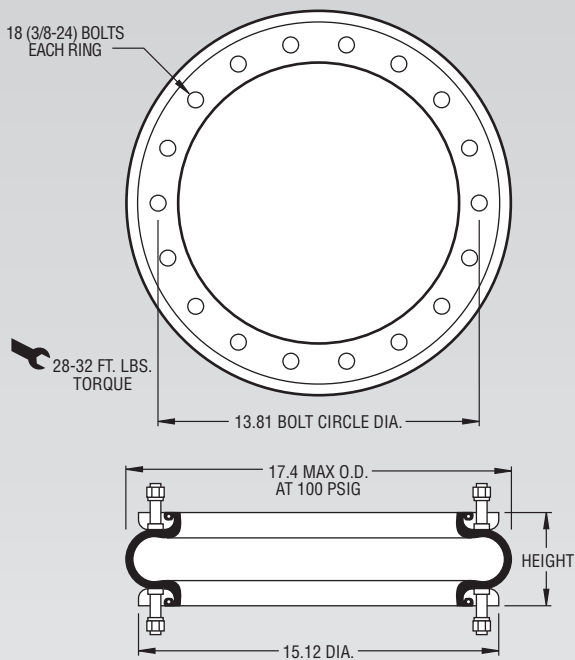

**NOTE: A bead plate part is shown. This part is also available with rolled plates. See page 11 for explanation.**

Recommended Design Position Static Pressure 0-100 psi  
 RECOMMENDED AIRMOUNT DESIGN HEIGHT 5.0 INCHES  
 Static Data 6948

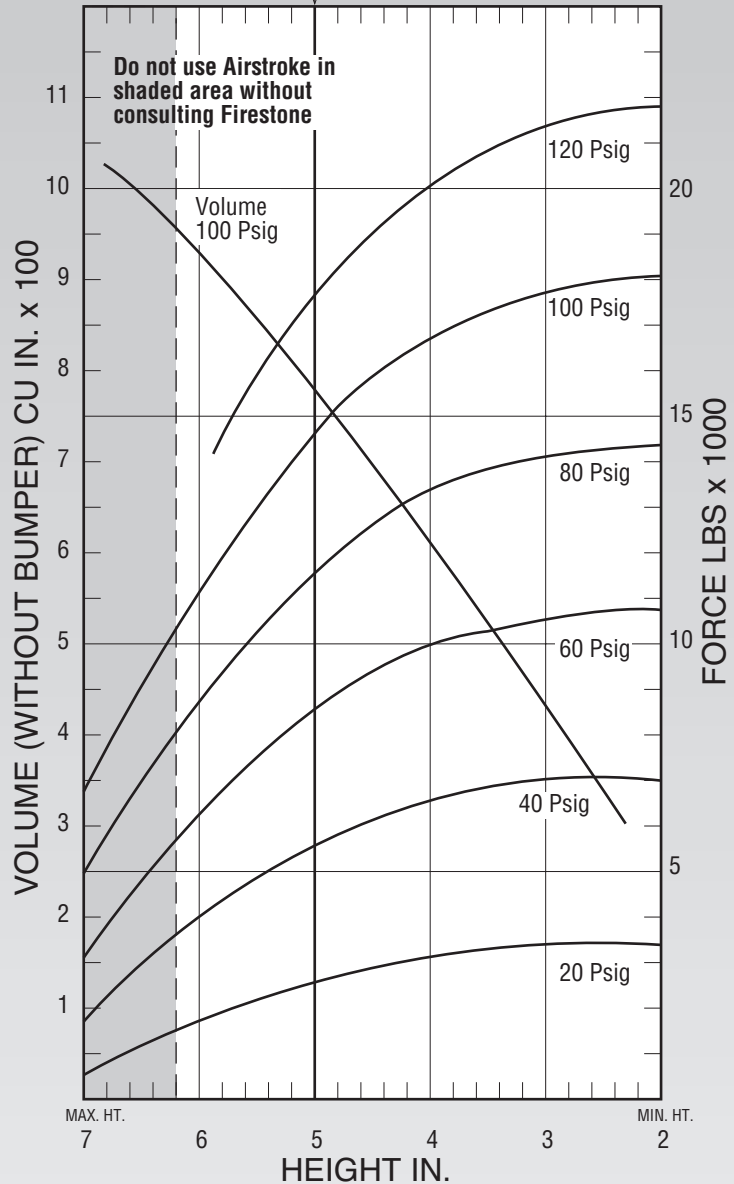

See page 12 for instructions on how to use chart.

Dynamic Characteristics at 5.0 in. Design Height (Required for Airmount isolator design only)				
Volume @ 100 PSIG = 787 in <sup>3</sup>			Natural Frequency	
Gage Pressure (PSIG)	Load (lbs.)	Spring Rate (lbs./in.)	CPM	HZ
40	5,490	3,478	149	2.49
60	8,450	4,880	143	2.38
80	11,450	6,186	138	2.30
100	14,520	7,523	135	2.25

Force Table (Use for Airstroke™ actuator design)						
Assembly Height (in.)	Volume @ 100 PSIG (in <sup>3</sup> )	Pounds Force				
		@20 PSIG	@40 PSIG	@60 PSIG	@80 PSIG	@100 PSIG
6.0	932	1,640	3,800	6,100	8,550	11,070
5.0	787	2,560	5,490	8,450	11,450	14,520
4.0	617	3,080	6,470	9,850	13,190	16,600
3.0	436	3,310	6,920	10,530	14,030	17,630