

	Description	Assembly Order No.
Style 19-.75	Blind nuts, 1/4 NPT	WO1-358-7040
	Blind nuts, 1/4 NPT rubber bumper	WO1-358-7039
Two Ply Bellows	Blind nuts, 3/4 NPT	WO1-358-7042
	Blind nuts, 3/4 NPT rubber bumper	WO1-358-7043
	Counter-sunk steel bead rings, 1 5/8 bolts, nuts, washers	WO1-358-6896
Assembly weight		10.0 lbs.
Force to collapse to minimum height (@ 0 PSIG).....		15 lbs.

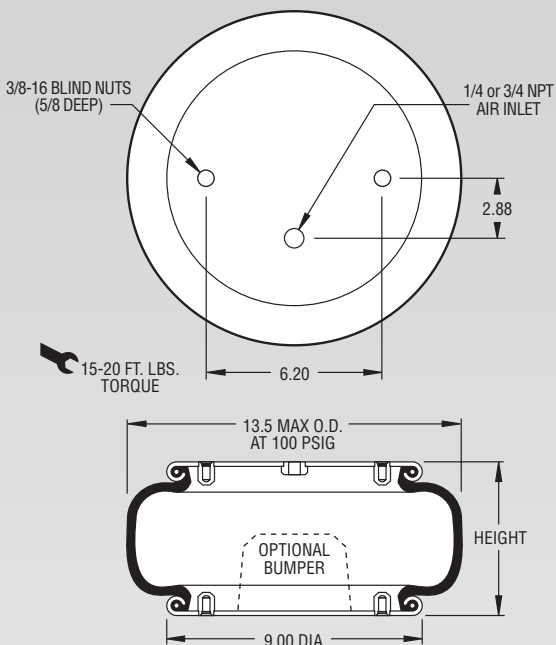

NOTE: A bead plate part is shown. This part is also available with bead rings. See pages 8-10 for explanation.

Dynamic Characteristics at 5.5 in. Design Height (Required for Airmount isolator design only)				
Volume @ 100 PSIG = 470 in ³			Natural Frequency	
Gage Pressure (PSIG)	Load (lbs.)	Spring Rate (lbs./in.)	CPM	HZ
40	1,890	1,544	170	2.83
60	2,950	2,203	162	2.70
80	4,080	2,829	156	2.60
100	5,260	3,448	152	2.53

Recommended Design Position Static Pressure 0-100 psi
RECOMMENDED AIRMOUNT DESIGN HEIGHT 5.5 INCHES
Static Data C0021

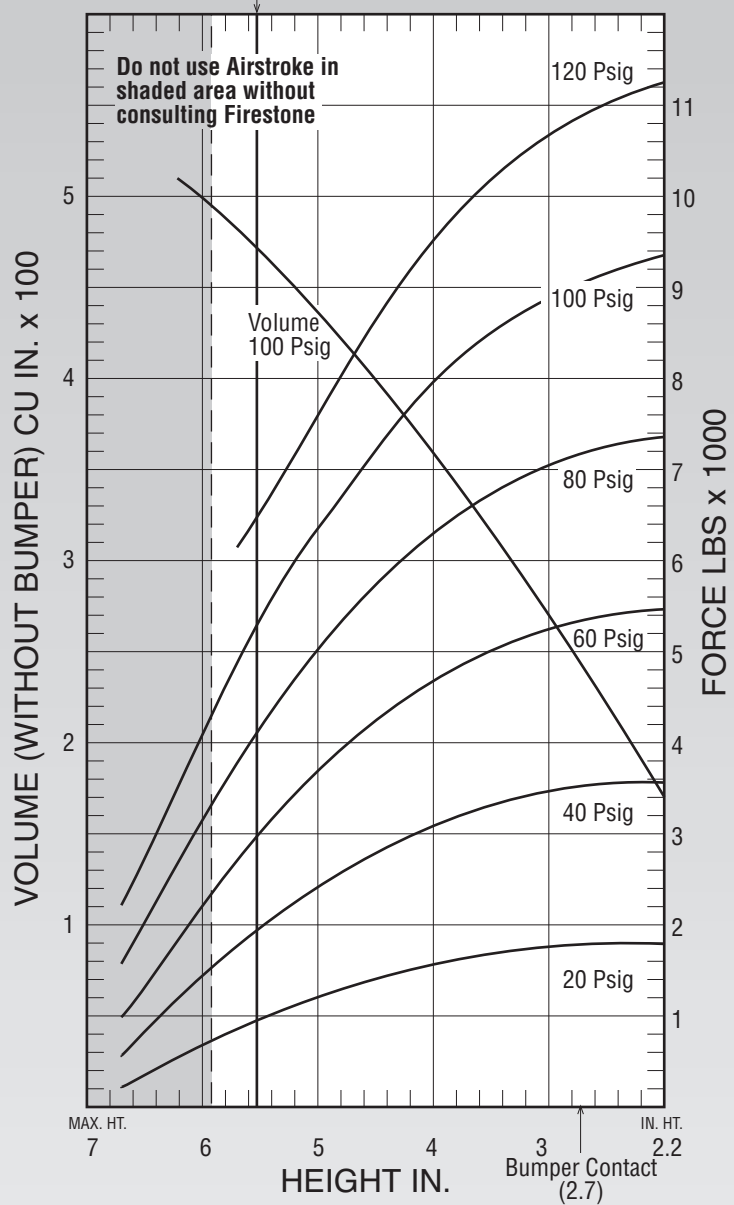

See page 12 for instructions on how to use chart.

Force Table (Use for Airstroke™ actuator design)						
Assembly Height (in.)	Volume @ 100 PSIG (in ³)	Pounds Force				
		@20 PSIG	@40 PSIG	@60 PSIG	@80 PSIG	@100 PSIG
5.0	438	1,190	2,390	3,670	5,000	6,360
4.0	359	1,560	3,110	4,710	6,330	7,980
3.0	270	1,730	3,460	5,240	7,040	8,850