

Description		Assembly Order No.
Style 1M1A-1	Blind nut, 1/8 NPT, brass stud	WO2-358-3003
Two Ply Bellows		
Assembly weight .....		0.5 lbs.
Force to collapse to minimum height (@ 0 PSIG) .....		20 lbs.

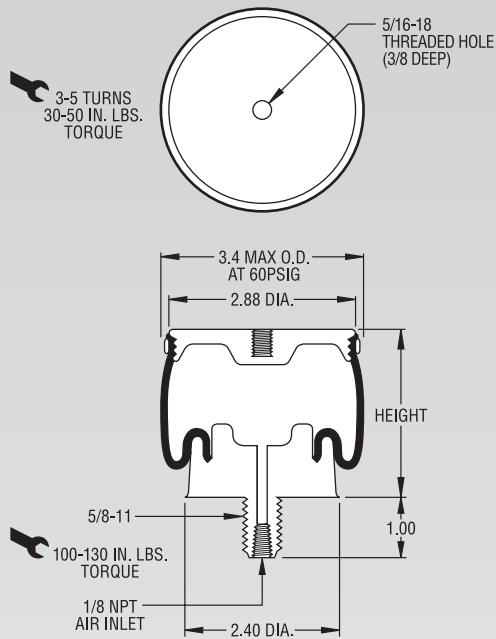

**NOTE:** The dotted line on the static data chart shows the force capabilities of the 1M1A-1 when attaching an additional 0.5 inch pedestal, provided by the customer, to the base of the air spring. If an additional pedestal is not used, the air spring will behave as the solid line depicts. Without a pedestal the rubber part will contact the ground at the height of 2.1 inches and could cause the rubber part to wear prematurely.

Dynamic Characteristics at 3.0 in. Design Height (Required for Airmount isolator design only)				
Volume @ 100 PSIG = 14 in <sup>3</sup>			Natural Frequency	
Gage Pressure (PSIG)	Load (lbs.)	Spring Rate (lbs./in.)	CPM	HZ
40	235	191	199.52	3.33
60	356	274	169.93	2.83
80	475	352	161.74	2.70
100	593	458	165.29	2.75

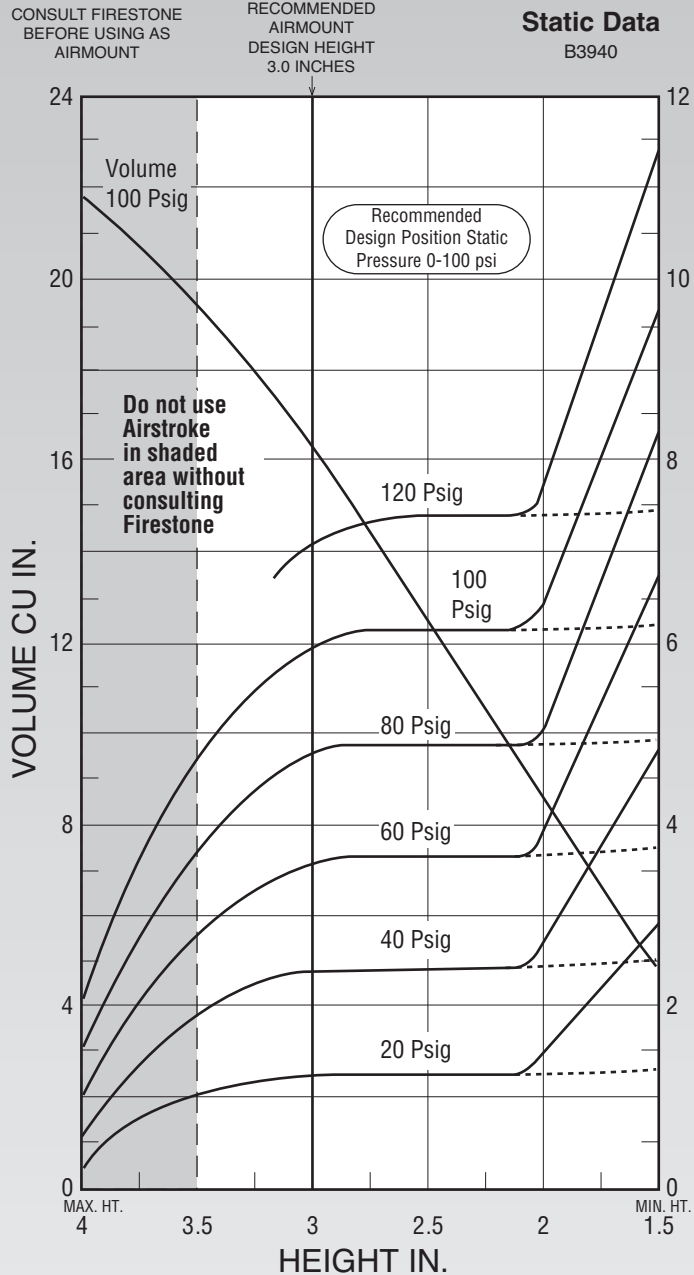

See page 12 for instructions on how to use chart.

Force Table (Use for Airstroke™ actuator design)						
Assembly Height (in.)	Volume @ 100 PSIG (in <sup>3</sup> )	Pounds Force				
		@20 PSIG	@40 PSIG	@60 PSIG	@80 PSIG	@100 PSIG
3.0	14	118	235	356	475	593