

Description		Assembly Order No.
Style 1T14C-3	Blind nuts, 1/4 NPT	WO1-358-5405
Two Ply Bellows		
Assembly weight		6.8 lbs.

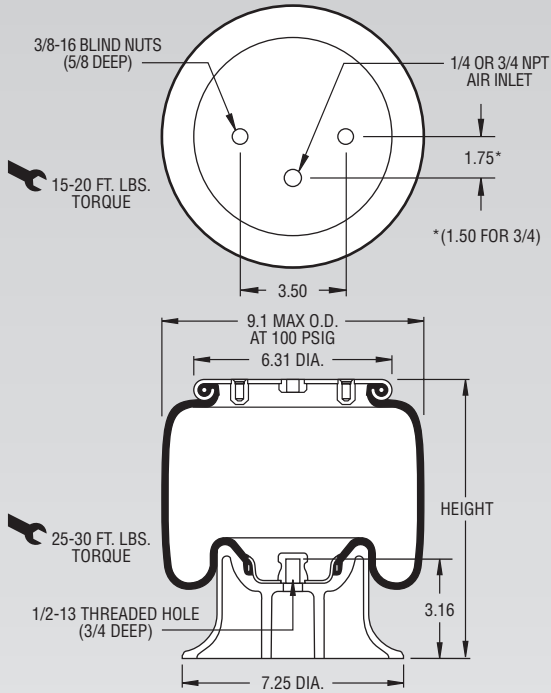

NOTE: Bellows will not compress properly with less than 10 PSIG internal pressure.

NOTE: A bead plate part is shown. This part is also available with a bead ring. Bolts are not included. See pages 8-10 for explanation.

Dynamic Characteristics at 10.0 in. Design Height (Required for Airmount isolator design only)				
Volume @ 100 PSIG = 313 in ³			Natural Frequency	
Gage Pressure (PSIG)	Load (lbs.)	Spring Rate (lbs./in.)	CPM	HZ
40	1,180	280	92	1.53
60	1,810	356	83	1.39
80	2,450	453	81	1.35
100	3,120	552	79	1.32

CONSULT FIRESTONE BEFORE USING AS AIRMOUNT

RECOMMENDED AIRMOUNT DESIGN HEIGHT 10.0 INCHES

Static Data 3018

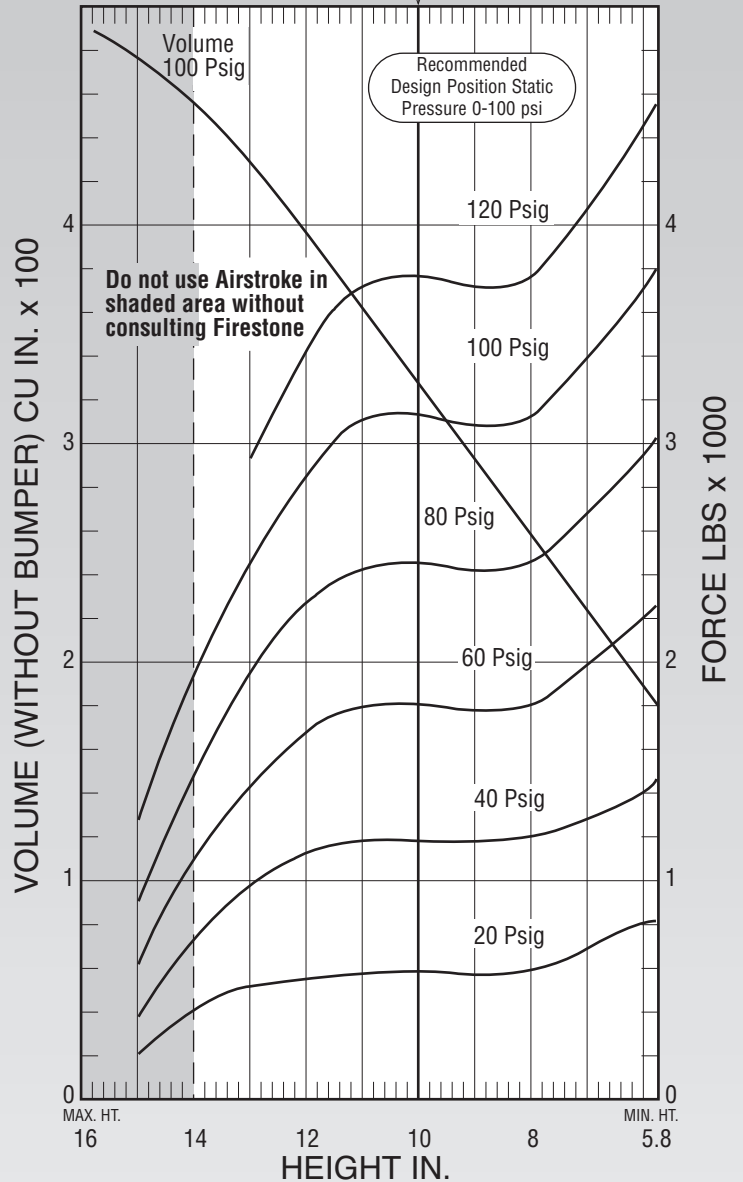

See page 12 for instructions on how to use chart.

Force Table (Use for Airstroke™ actuator design)						
Assembly Height (in.)	Volume @ 100 PSIG (in ³)	Pounds Force				
		@20 PSIG	@40 PSIG	@60 PSIG	@80 PSIG	@100 PSIG
14.0	430	410	730	1,080	1,490	1,960
12.0	378	560	1,120	1,680	2,280	2,870
10.0	313	580	1,170	1,820	2,440	3,130
8.0	246	610	1,190	1,810	2,430	3,110
6.0	176	800	1,500	2,180	2,960	3,740