

Description		Assembly Order No.
Style 1T15L-4	Blind nuts, 1/4 NPT	WO1-358-9414
Two Ply Bellows		
Assembly weight		15.5 lbs.

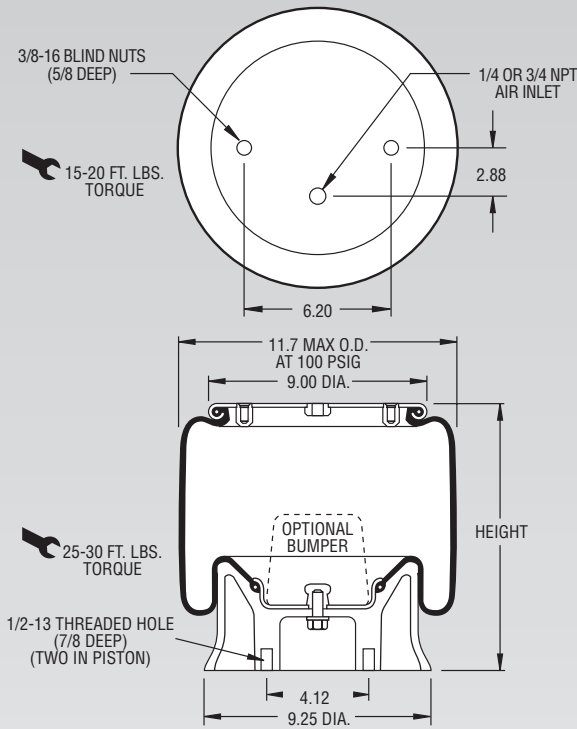

NOTE: Bellows will not compress properly with less than 10 PSIG internal pressure.

NOTE: A bead plate part is shown. This part is also available with a bead ring. Bolts are not included. See pages 8-10 for explanation.

CONSULT FIRESTONE BEFORE USING AS AIRMOUNT

RECOMMENDED AIRMOUNT DESIGN HEIGHT 11.0 INCHES

Static Data
3105

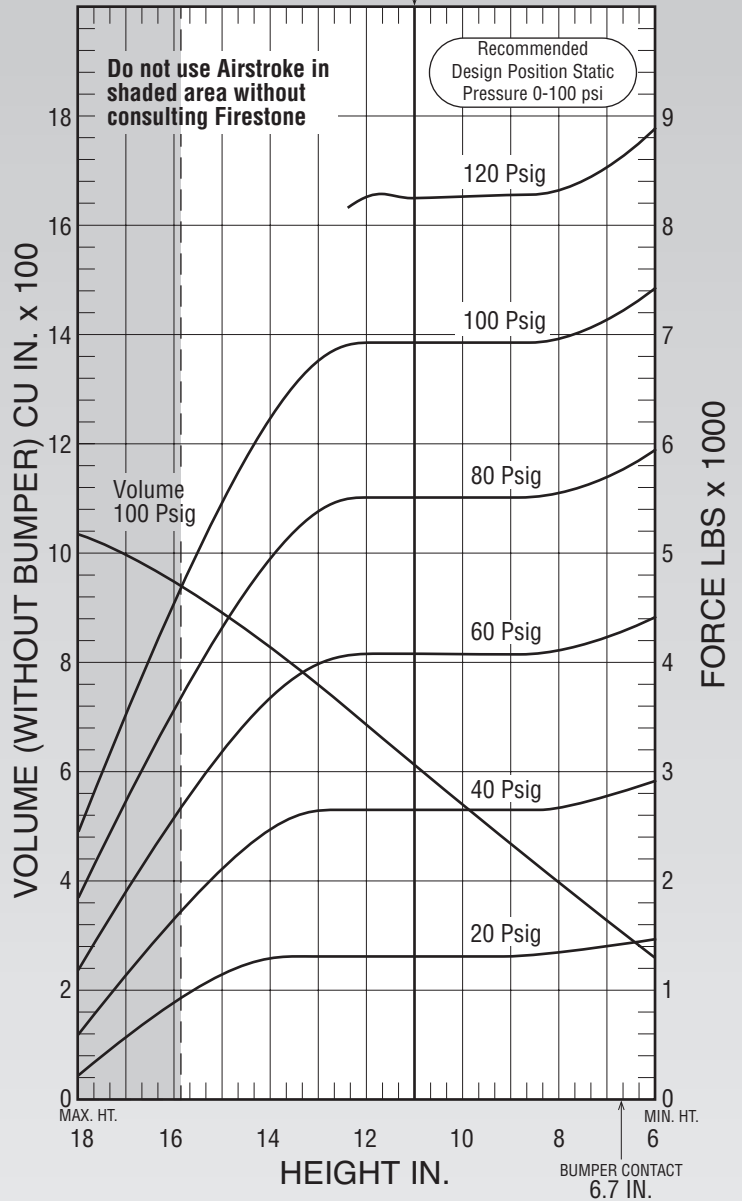

See page 12 for instructions on how to use chart.

Dynamic Characteristics at 11.0 in. Design Height (Required for Airmount isolator design only)				
Volume @ 100 PSIG = 625 in ³			Natural Frequency	
Gage Pressure (PSIG)	Load (lbs.)	Spring Rate (lbs./in.)	CPM	HZ
40	2,650	583	88	1.47
60	4,080	823	84	1.40
80	5,510	1,055	82	1.37
100	6,930	1,281	81	1.34

Force Table (Use for Airstroke™ actuator design)						
Assembly Height (in.)	Volume @ 100 PSIG (in ³)	Pounds Force				
		@20 PSIG	@40 PSIG	@60 PSIG	@80 PSIG	@100 PSIG
15.0	898	1,120	2,110	3,150	4,300	5,440
13.0	768	1,310	2,630	3,970	5,360	6,720
11.0	625	1,310	2,650	4,080	5,510	6,930
9.0	479	1,310	2,650	4,080	5,500	6,920
7.0	333	1,390	2,780	4,210	5,690	7,120