

Description		Assembly Order No.
Style 29	Ribbed neck aluminum bead rings (equal spacing), 1 7/8 bolts, nuts, washers	WO1-358-7203
Two Ply Bellows	Ribbed neck aluminum bead rings (unequal spacing) 1 7/8 b,n,w	WO1-358-7205
	Ribbed neck aluminum bead rings (equal spacing) 1 1/4 b,n,w	WO1-358-7201
	Rolled plate assembly, 1/2 blind nuts 3/4 NPT	WO1-358-7275
	Rubber bellows only	WO1-358-7902
Assembly weight		28.8 lbs
Force to collapse to minimum height (@ 0 PSIG).....		70 lbs.

Style 207	Ribbed neck aluminum bead rings (equal spacing), 1 7/8 bolts, nuts, washers	WO1-358-7242
High Strength Bellows	Ribbed neck aluminum bead rings (unequal spacing) 1 7/8 b,n,w	WO1-358-7239
	Rubber bellows only	WO1-139-0207

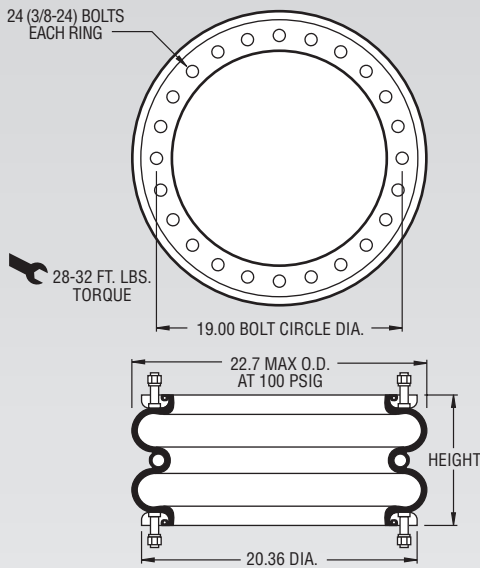

NOTE: A bead ring part is shown. This part is also available with rolled plates. See page 11 for explanation

Dynamic Characteristics at 9.5 in. Design Height (Required for Airmount isolator design only)				
Volume @ 100 PSIG = 2,934 in ³			Natural Frequency	
Gage Pressure (PSIG)	Load (lbs.)	Spring Rate (lbs./in.)	CPM	HZ
40	9,780	2,752	96	1.60
60	14,860	3,737	94	1.57
80	20,060	4,844	92	1.54
100	25,350	5,917	91	1.51

Recommended Design Position Static Pressure 0-100 psi
 RECOMMENDED AIRMOUNT DESIGN HEIGHT 9.5 INCHES
 Static Data 5532

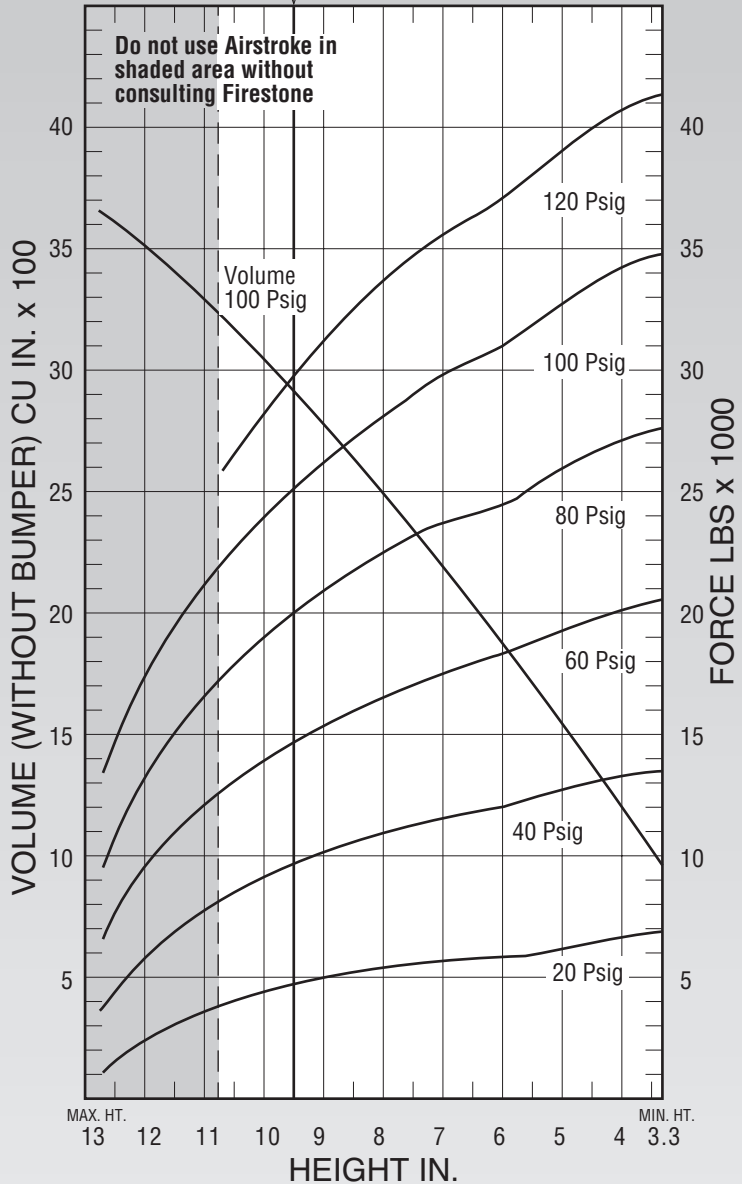

See page 12 for instructions on how to use chart.

Force Table (Use for Airstroke™ actuator design)						
Assembly Height (in.)	Volume @ 100 PSIG (in ³)	Pounds Force				
		@20 PSIG	@40 PSIG	@60 PSIG	@80 PSIG	@100 PSIG
10.0	3,064	4,480	9,320	14,130	19,110	24,190
9.0	2,796	4,990	10,200	15,520	20,940	26,410
8.0	2,512	5,440	10,990	16,680	22,480	28,270
7.0	2,206	5,780	11,650	17,620	23,740	29,830
6.0	1,889	5,950	12,090	18,330	24,640	31,000
5.0	1,559	6,310	12,720	19,340	26,040	32,740
4.0	1,211	6,650	13,320	20,150	27,140	34,100