

Description		Assembly Order No.
Style 7002	Blind nut, 1/8 NPT	WO2-358-7002
Two Ply Bellows		
Assembly weight .....		1.8 lbs.

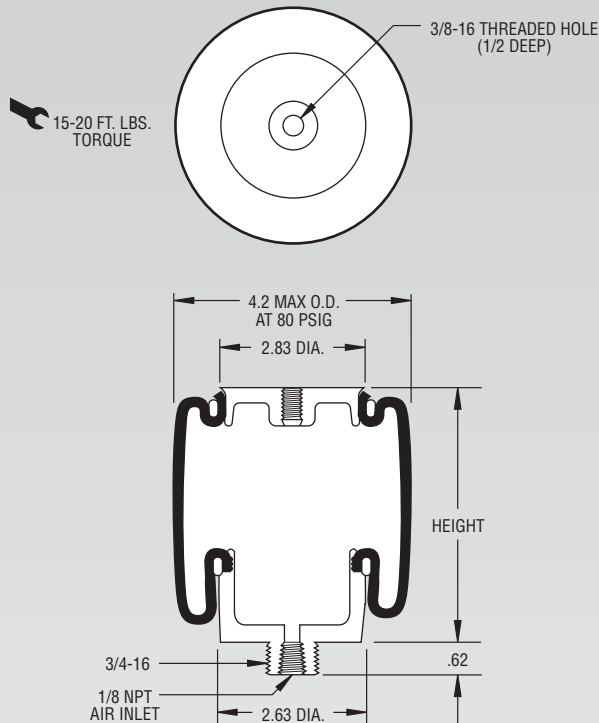

**NOTE:** Bellows will not compress properly with less than 10 PSIG internal pressure.

CONSULT FIRESTONE BEFORE USING AS AIRMOUNT

RECOMMENDED AIRMOUNT DESIGN HEIGHT 4.5 INCHES

**Static Data**  
8609

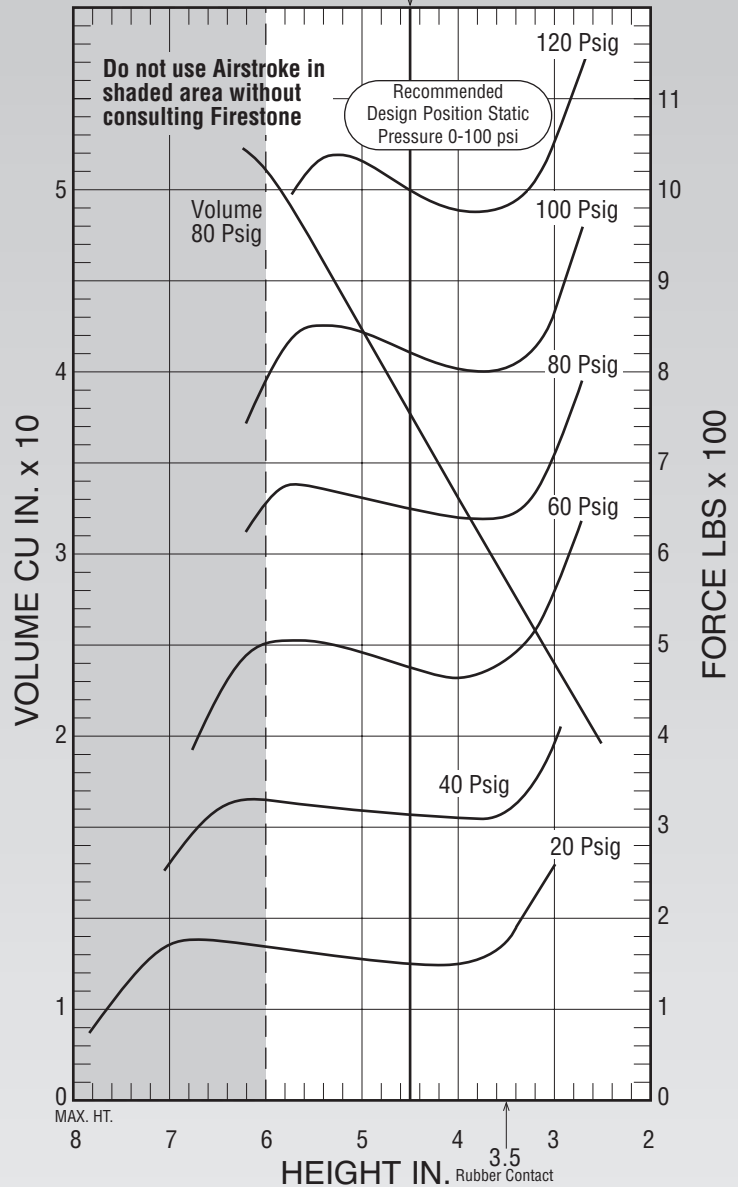

See page 12 for instructions on how to use chart.

Dynamic Characteristics at 4.5 in. Design Height (Required for Airmount isolator design only)				
Volume @ 80 PSIG = 37 in <sup>3</sup>			Natural Frequency	
Gage Pressure (PSIG)	Load (lbs.)	Spring Rate (lbs./in.)	CPM	HZ
40	310	137	124	2.07
60	480	178	114	1.91
80	650	239	114	1.89
100	820	280	110	1.81

Force Table (Use for Airstroke™ actuator design)						
Assembly Height (in.)	Volume @ 80 PSIG (in <sup>3</sup> )	Pounds Force				
		@20 PSIG	@40 PSIG	@60 PSIG	@80 PSIG	@100 PSIG
6.0	50	170	330	510	680	860
5.0	42	150	320	490	660	840
4.0	33	150	310	470	640	800