

NOTE: All Assembly Order Numbers are for bead plate parts unless noted otherwise.

	Description	Assembly Order No.
Style 116	Blind nuts, 1/4 BSP	W01-M58-6166
	Blind nuts, 3/4 BSP	W01-M58-6165
Two Ply Bellows	Button head steel bead rings, 40 mm bolts, nuts & washers	SEE NOTE BELOW
	Rubber bellows only	W01-358-0133
Assembly weight.....		1.95 kg.
Force to collapse to minimum height (@ 0 BAR)		36 N.

Style 117	Description	Assembly Order No.
High Strength Construction	Blind nuts, 1/4 BSP	W01-M58-6176
	Blind nuts, 3/4 BSP	W01-M58-6175
	Button head steel bead rings, 40 mm bolts, nuts & washers	SEE NOTE BELOW

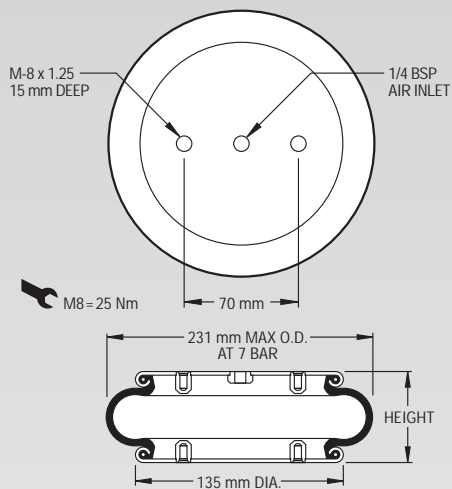

NOTE: A bead plate part is shown. This part is also available with bead rings. See pages 8-10 for explanation.

Dynamic Characteristics at 115 mm Design Height (Required for Airmount isolator design only)			
Gauge Pressure (BAR)	Load (kN)	Spring Rate (kN/m)	Natural Frequency Hz
3	4.16	132	2.80
4	5.73	169	2.71
5	7.26	207	2.67
6	8.98	247	2.62
7	10.55	285	2.59

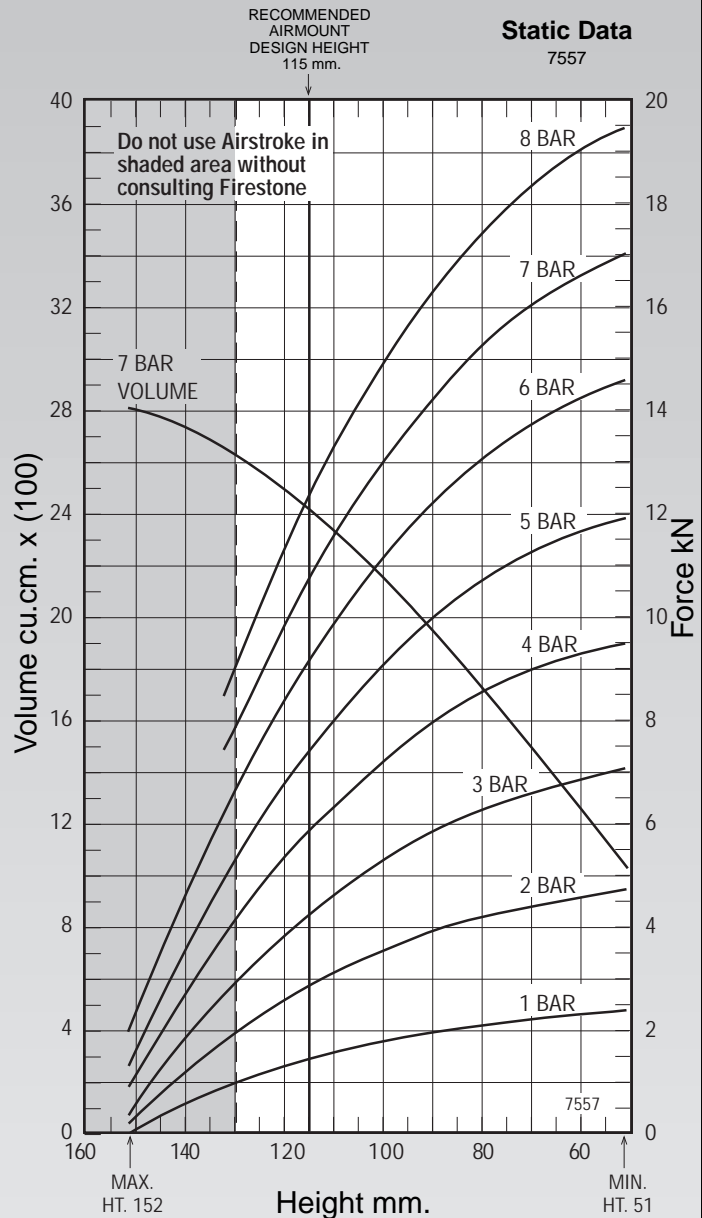

See page 12 for instructions on how to use chart.

Force Table (Use for Airstroke [®] actuator design)							
Assembly Height (mm)	Volume @ 7 BAR (cu cm)	EFF Area @ 7 BAR (cm**2)	kN Force				
			@ 3 BAR	@ 4 BAR	@ 5 BAR	@ 6 BAR	@ 7 BAR
130	2635	110	2.86	4.04	5.17	6.51	7.71
120	2506	138	3.75	5.20	6.60	8.20	9.65
110	2341	163	4.54	6.22	7.86	9.70	11.38
100	2164	183	5.20	7.07	8.92	10.95	12.82
90	1956	201	5.75	7.84	9.84	12.04	14.07
80	1745	215	6.19	8.45	10.59	12.91	15.08
70	1509	228	6.54	8.91	11.18	13.64	15.92
60	1280	236	6.82	9.20	11.58	14.17	16.55