

NOTE: All Assembly Order Numbers are for bead ring parts unless noted otherwise.

	Description	Assembly Order No.
Style 121	Ribbed neck aluminum bead rings, 45 mm bolts, nuts, washers	W01-M58-6966
Two Ply Bellows	Rolled plate assembly, 1/2 blind nuts, 3/4 BSP	SEE NOTE BELOW
	Rubber bellows only	W01-358-5135
Assembly weight.....		7.26 kg.
Force to collapse to minimum height (@ 0 BAR)		89 N.

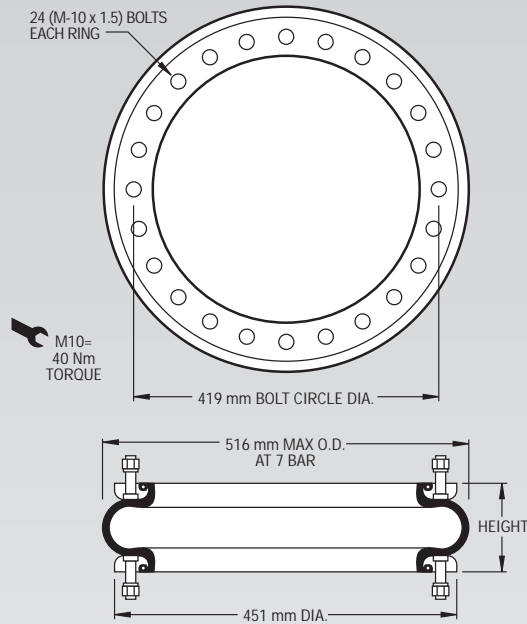

NOTE: A bead ring part is shown. This part is also available with rolled plates. See page 11 for explanation.

Dynamic Characteristics at 125 mm Design Height (Required for Airmount isolator design only)			
Gauge Pressure (BAR)	Load (kN)	Spring Rate (kN/m)	Natural Frequency Hz
3	32.46	812	2.49
4	45.13	1058	2.41
5	57.13	1298	2.38
6	70.61	1535	2.33
7	82.85	1750	2.29

RECOMMENDED
AIRMOUNT
DESIGN HEIGHT
125 mm.

Static Data
3944

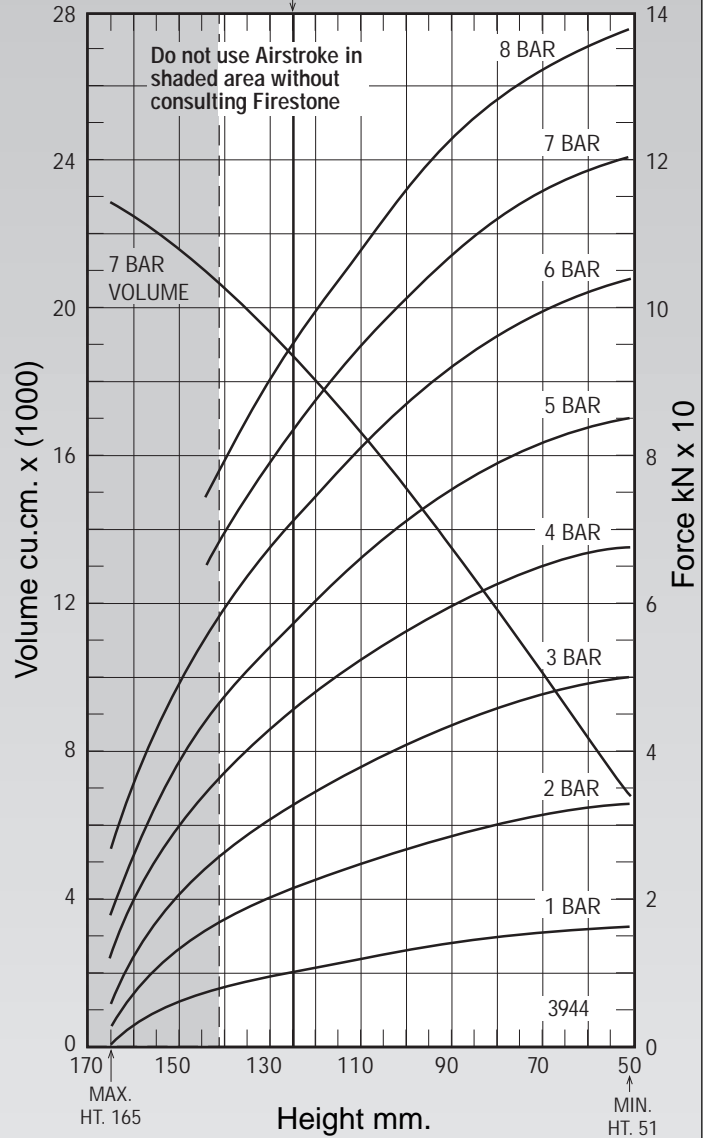

See page 12 for instructions on how to use chart.

Force Table (Use for Airstroke® actuator design)							
Assembly Height (mm)	Volume @ 7 BAR (cu cm)	EFF Area @ 7 BAR (cm sq)	kN Force				
			@ 3 BAR	@ 4 BAR	@ 5 BAR	@ 6 BAR	@ 7 BAR
130	19228	1122	30.41	42.47	53.82	66.78	78.52
120	17985	1239	34.26	47.49	60.07	74.04	86.72
110	16552	1350	37.72	52.13	65.82	80.82	94.46
100	15121	1446	40.64	56.07	70.70	86.63	101.20
90	13511	1531	43.26	59.58	74.98	91.75	107.17
80	11939	1599	45.55	62.46	78.47	95.84	111.88
70	10205	1653	47.72	64.98	81.51	99.23	115.66