

**NOTE: All Assembly Order Numbers are for bead ring parts unless noted otherwise.**

	Description	Assembly Order No.
Style 126	Ribbed neck aluminum bead rings (equal spacing), 45 mm bolts, nuts, washers	W01-M58-6973
Two Ply Bellows	Rolled plate assembly, 1/2 blind nuts, 3/4 BSP	SEE NOTE BELOW
	Rubber bellows only	W01-358-1026
Assembly weight.....		9.66 kg.
Force to collapse to minimum height (@ 0 BAR)		111 N.

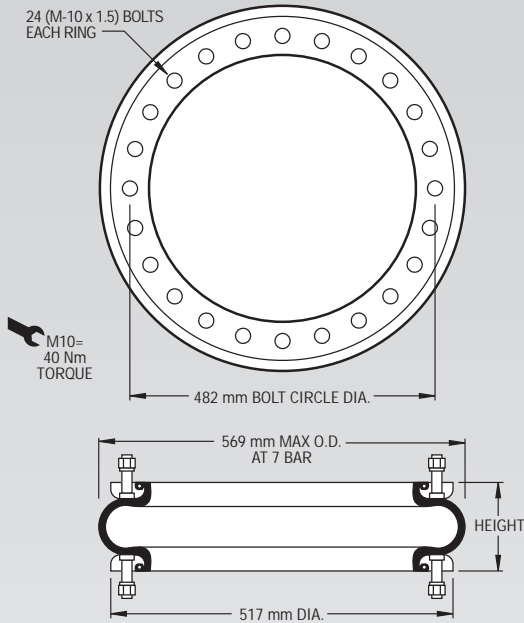

**NOTE: A bead ring part is shown. This part is also available with rolled plates. See page 11 for explanation.**

Dynamic Characteristics at 125 mm Design Height (Required for Airmount isolator design only)			
Gauge Pressure (BAR)	Load (kN)	Spring Rate (kN/m)	Natural Frequency Hz
3	53.10	1184	2.35
4	71.42	1512	2.29
5	89.75	1828	2.25
6	109.40	2154	2.21
7	127.49	2458	2.19

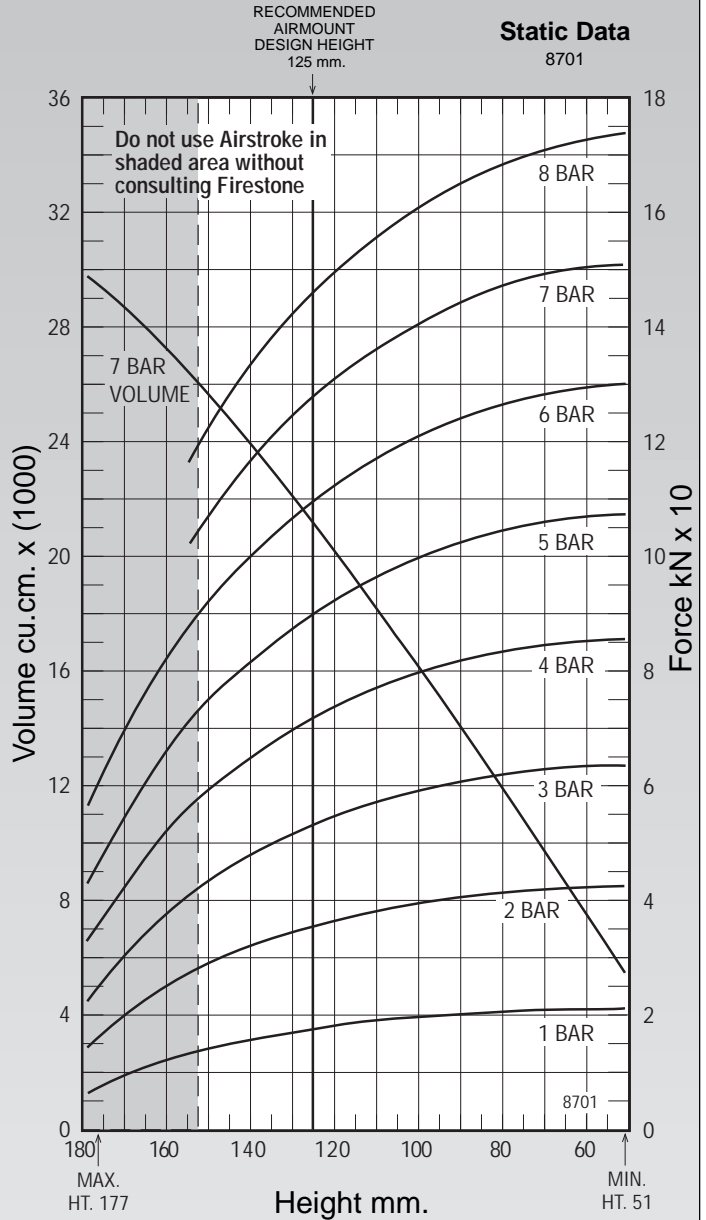

See page 12 for instructions on how to use chart.

Force Table (Use for Airstroke <sup>®</sup> actuator design)							
Assembly Height (mm)	Volume @ 7 BAR (cu cm)	EFF Area @ 7 BAR (cm sq)	kN Force				
			@ 3 BAR	@ 4 BAR	@ 5 BAR	@ 6 BAR	@ 7 BAR
160	27186	1355	37.05	51.09	64.81	80.58	94.86
140	23871	1660	47.71	64.48	81.24	99.48	116.20
120	20206	1863	54.46	73.23	91.96	111.95	130.41
100	16216	2006	58.95	79.48	99.52	120.68	140.38
80	12022	2101	62.03	83.35	104.45	126.58	147.09
60	7743	2153	63.76	85.23	106.86	129.60	150.66