

	Description	Assembly Order No.
Style 1M1A-0	Blind nuts, 1/8 BSP, Plastic stud	W02-M58-3000
Two Ply Bellows	Blind nuts, 1/8 BSP, Brass stud	W02-M58-3001
Assembly weight23 kg.
Force to collapse to minimum height (@ 0 BAR)		89 N.

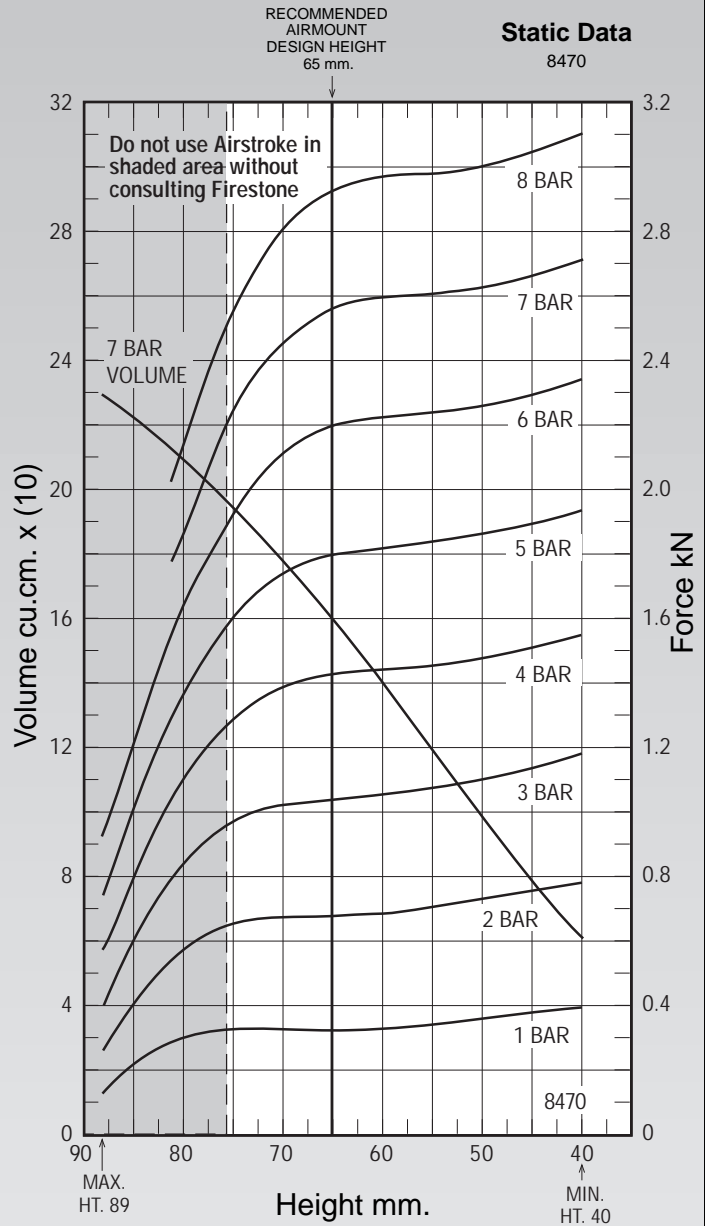
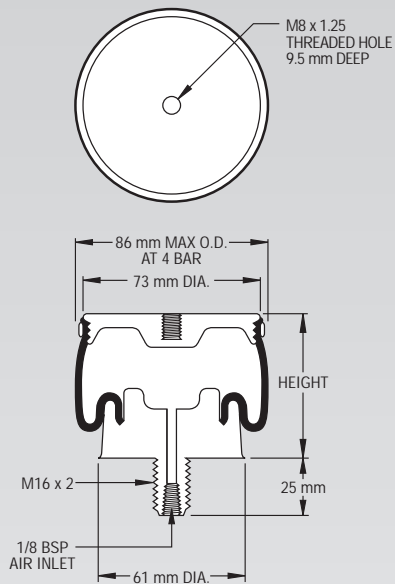

See page 12 for instructions on how to use chart.

Dynamic Characteristics at 65 mm Design Height (Required for Airmount isolator design only)			
Gauge Pressure (BAR)	Load (kN)	Spring Rate (kN/m)	Natural Frequency Hz
3	1.04	53	3.58
4	1.42	70	3.49
5	1.79	86	3.45
6	2.19	103	3.42
7	2.55	118	3.40

Force Table (Use for Airstroke® actuator design)							
Assembly Height (mm)	Volume @ 7 BAR (cu cm)	EFF Area @ 7 BAR (cm sq)	kN Force				
			@ 3 BAR	@ 4 BAR	@ 5 BAR	@ 6 BAR	@ 7 BAR
70	180	35	1.02	1.38	1.72	2.09	2.42
65	161	36	1.04	1.42	1.79	2.19	2.55
60	144	37	1.05	1.44	1.82	2.22	2.59
55	123	37	1.07	1.45	1.83	2.23	2.60
50	103	37	1.10	1.47	1.85	2.25	2.62
45	81	38	1.13	1.50	1.89	2.29	2.65
40	64	39	1.17	1.54	1.93	2.33	2.70