

Description		Assembly Order No.
Style 1M1A-1	Blind nuts, 1/8 BSP	W02-M58-3006
Two Ply Bellows		
Assembly weight .....		.23 kg.
Force to collapse to minimum height (@ 0 BAR) .....		89 N.

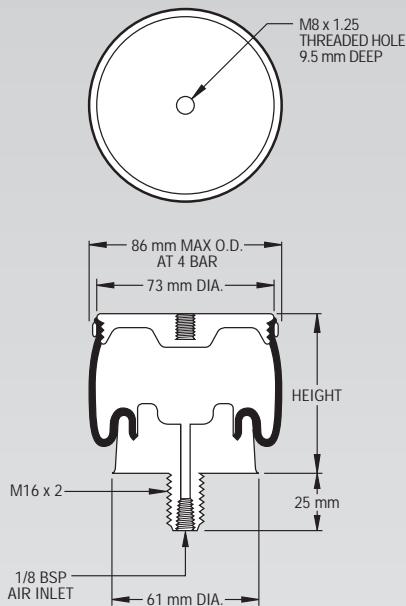

**NOTE:** The dotted line on the static data chart shows the force capabilities of the 1M1A-1 when attaching an additional 12 mm pedestal, provided by the customer, to the base of the air spring. If an additional pedestal is not used, the air spring will behave as the solid line depicts. Without a pedestal the rubber part will contact the ground at the height of 53 mm and could cause the rubber part to wear prematurely.

Gauge Pressure (BAR)	Load (kN)	Spring Rate (kN/m)	Natural Frequency Hz
3	1.16	38.66	2.88
4	1.57	49.85	2.81
5	1.97	60.30	2.76
6	2.39	71.66	2.73
7	2.78	81.97	2.71

RECOMMENDED AIRMOUNT DESIGN HEIGHT 75 mm.  
**Static Data**  
A9618

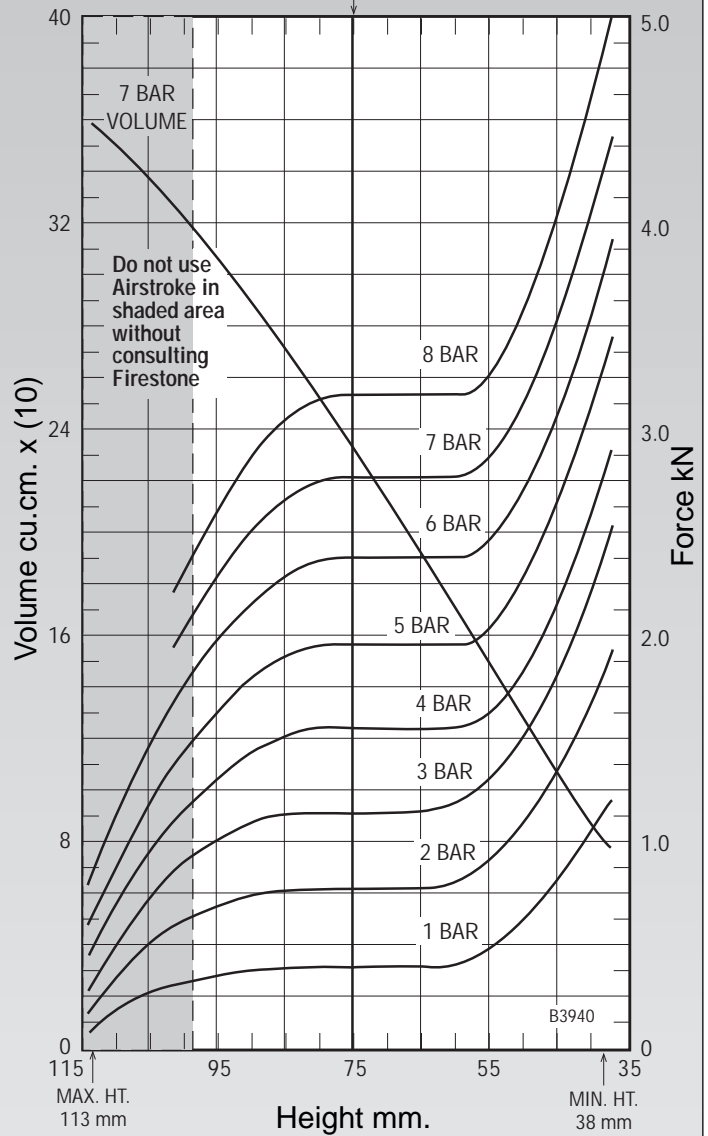

See page 12 for instructions on how to use chart.

Assembly Height (mm)	Volume @ 7 BAR (cu cm)	EFF Area @ 7 BAR (cm sq)	kN Force				
			@ 3 BAR	@ 4 BAR	@ 5 BAR	@ 6 BAR	@ 7 BAR
85	272	38.07	1.14	1.52	1.95	2.30	2.66
75	235	39.67	1.16	1.57	1.97	2.39	2.78
65	194	39.67	1.16	1.57	1.97	2.39	2.78
55	152	40.83	1.31	1.63	2.04	2.46	2.86
45	110	50.25	1.79	2.17	2.63	3.06	3.52