

NOTE: All Assembly Order Numbers are for bead ring parts unless noted otherwise.

	Description	Assembly Order No.
Style 200	Ribbed neck aluminum bead rings (equal spacing), 45 mm bolts, nuts, washers	W01-M58-6979
Two Ply Bellows	Rubber bellows only	W01-358-5126
Assembly weight.....		15.83 kg.
Force to collapse to minimum height (@ 0 BAR)		445 N.

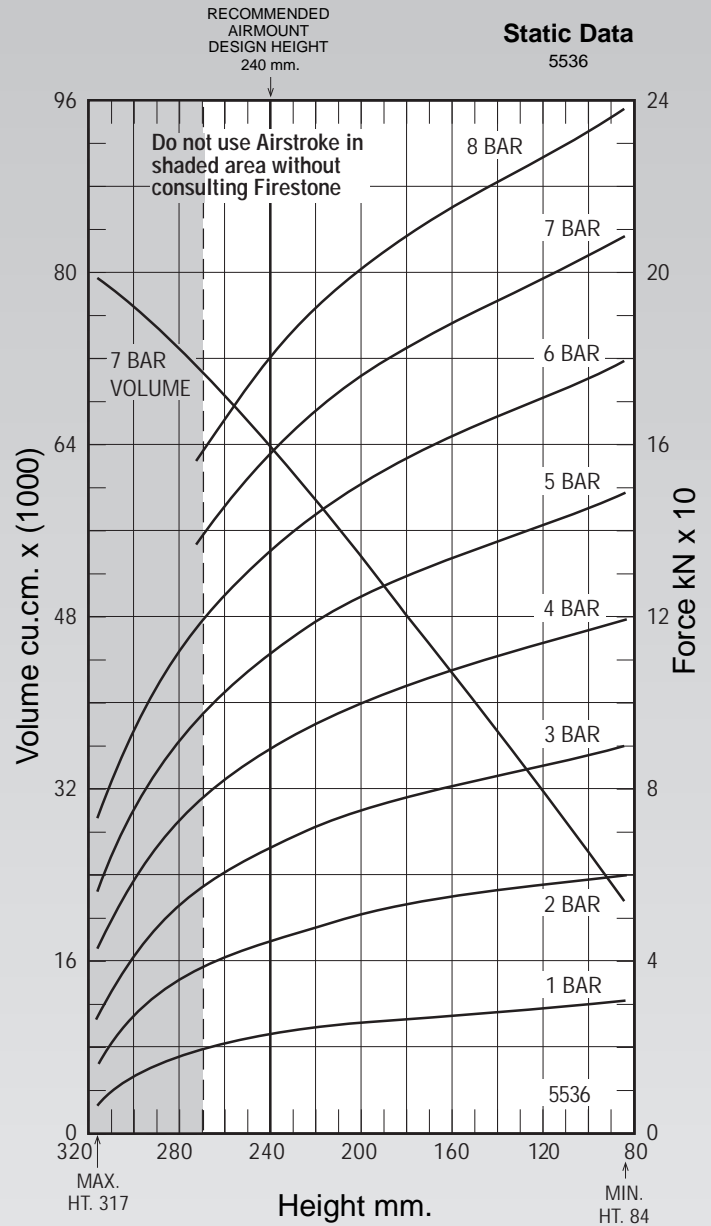
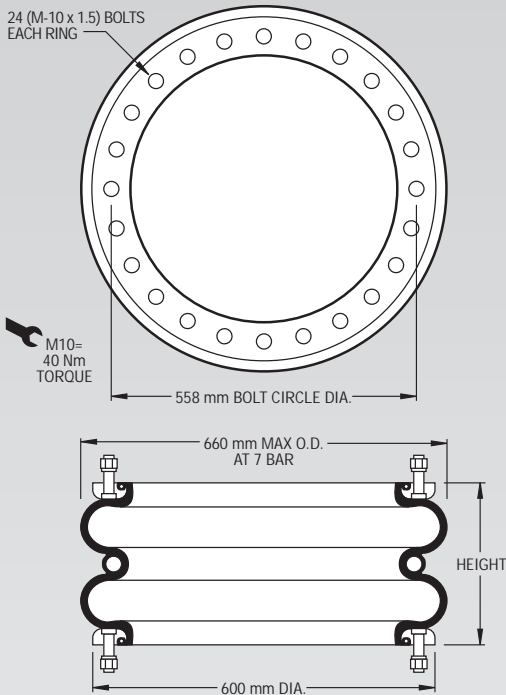

See page 12 for instructions on how to use chart.

Dynamic Characteristics at 240 mm Design Height (Required for Airmount isolator design only)			
Gauge Pressure (BAR)	Load (kN)	Spring Rate (kN/m)	Natural Frequency Hz
3	65.60	710	1.64
4	88.20	903	1.60
5	110.53	1091	1.57
6	134.38	1290	1.54
7	156.56	1480	1.53

Force Table (Use for Airstroke® actuator design)							
Assembly Height (mm)	Volume @ 7 BAR (cu cm)	EFF Area @ 7 BAR (cm sq)	kN Force				
			@ 3 BAR	@ 4 BAR	@ 5 BAR	@ 6 BAR	@ 7 BAR
260	68626	2057	59.56	80.57	101.22	123.62	143.98
240	64100	2237	65.60	88.20	110.53	134.38	156.56
220	59270	2384	70.27	94.34	117.99	143.23	166.86
200	54018	2503	74.03	99.30	124.00	150.38	175.20
180	48552	2599	77.11	103.27	128.85	156.12	181.87
160	42927	2678	79.74	106.59	132.92	160.96	187.47
140	37197	2754	82.19	109.71	136.77	165.54	192.76
120	31597	2835	84.73	113.02	140.90	170.45	198.42