

**NOTE: All Assembly Order Numbers are for bead ring parts unless noted otherwise.**

	Description	Assembly Order No.
Style 203	Ribbed neck aluminum bead rings (equal spacing), 45 mm bolts, nuts, washers	W01-M58-6985
Two Ply Bellows	Rolled plate assembly, 1/2 blind nuts, 3/4 NPT	SEE NOTE BELOW
	Rubber bellows only	W01-358-0205
Assembly weight.....		10.80 kg.
Force to collapse to minimum height (@ 0 BAR)		178 N.

Style 218	Ribbed neck aluminum bead rings (equal spacing), 45 mm bolts, nuts, washers	W01-M58-6986
High Strength Construction	Rubber bellows only	W01-358-0219

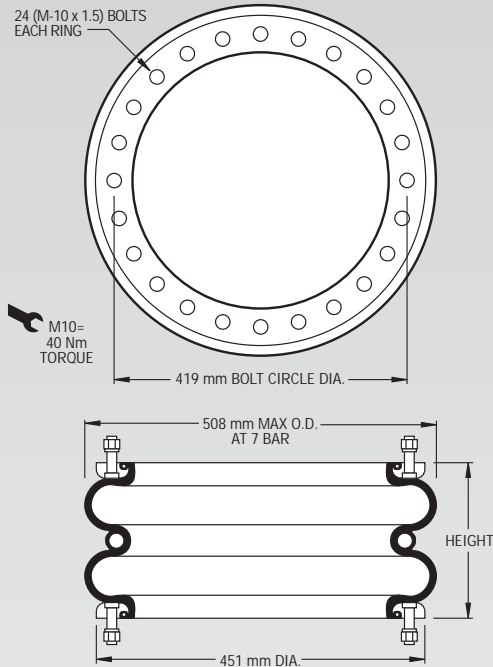

**NOTE: A bead ring part is shown. This part is also available with rolled plates. See page 11 for explanation.**

**Dynamic Characteristics at 240 mm Design Height**  
(Required for Airmount isolator design only)

Gauge Pressure (BAR)	Load (kN)	Spring Rate (kN/m)	Natural Frequency Hz
3	35.98	409	1.68
4	48.73	516	1.62
5	61.33	627	1.60
6	74.72	745	1.57
7	86.97	856	1.56

RECOMMENDED  
AIRMOUNT  
DESIGN HEIGHT  
240 mm.

**Static Data**  
6217

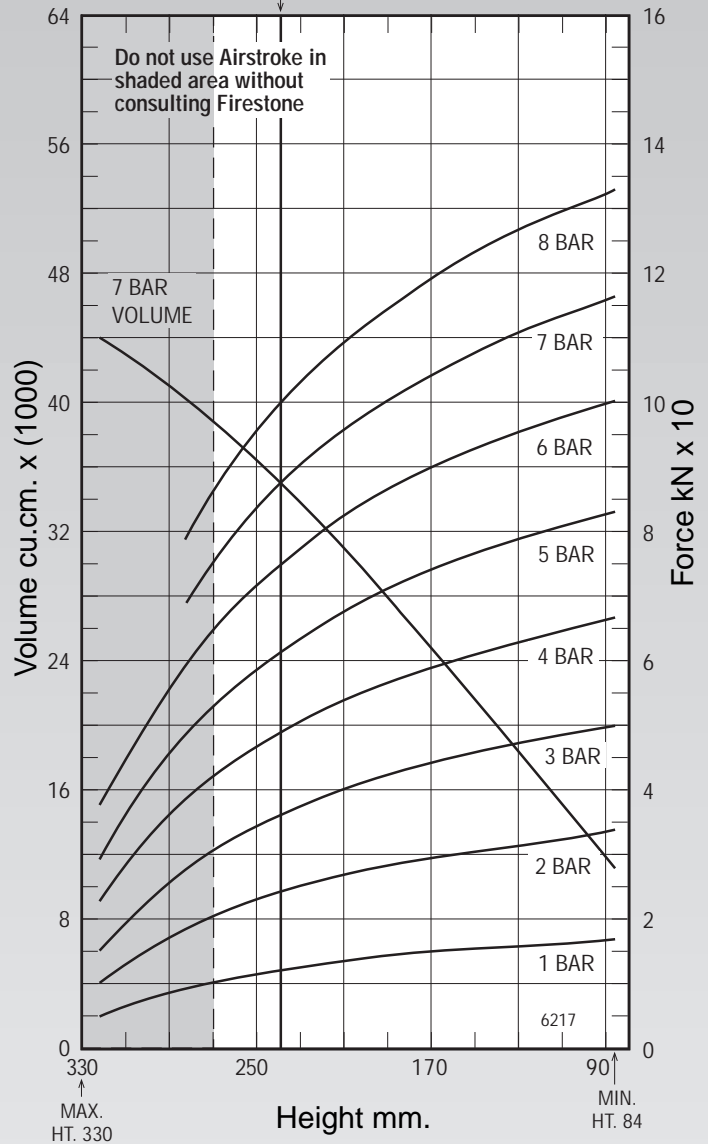

See page 12 for instructions on how to use chart.

**Force Table (Use for Airstroke® actuator design)**

Assembly Height (mm)	Volume @ 7 BAR (cu cm)	EFF Area @ 7 BAR (cm sq)	kN Force				
			@ 3 BAR	@ 4 BAR	@ 5 BAR	@ 6 BAR	@ 7 BAR
260	37836	1132	32.38	44.21	55.77	68.08	79.26
240	35328	1243	35.98	48.73	61.33	74.72	86.97
220	32638	1331	38.91	52.40	65.84	80.08	93.18
200	29694	1404	41.34	55.43	69.58	84.51	98.30
180	26610	1467	43.38	57.99	72.78	88.32	102.65
160	23416	1520	45.15	60.21	75.56	91.62	106.42
140	20139	1567	46.72	62.20	77.99	94.46	109.68
120	16912	1607	48.13	64.04	80.11	96.86	112.48