

**NOTE: All Assembly Order Numbers are for bead ring parts unless noted otherwise.**

	Description	Assembly Order No.
Style 321	Aluminum ribbed neck bead rings (equal spacing), 45 mm bolts, nuts, washers	W01-M58-6984
High Strength Construction	Rubber bellows only	W01-358-7919
Assembly weight.....		23.2 kg.
Force to collapse to minimum height (@ 0 BAR)		800 N.

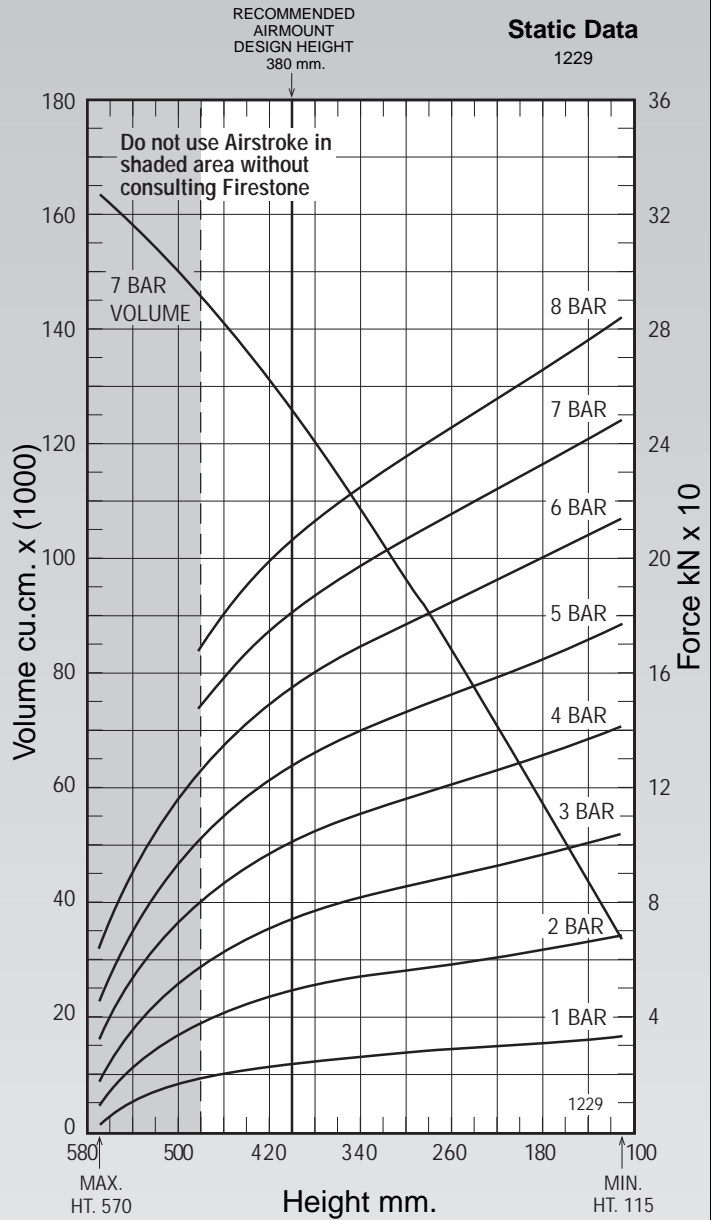
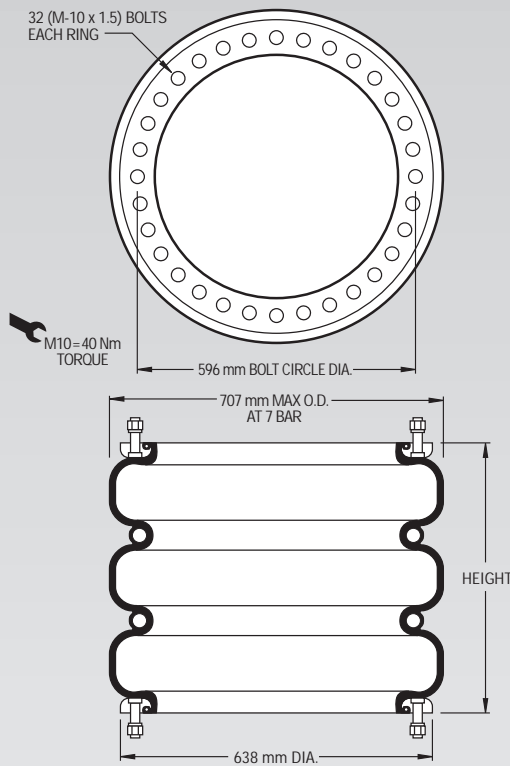

See page 12 for instructions on how to use chart.

**Dynamic Characteristics at 380 mm Design Height**  
(Required for Airmount isolator design only)

Gauge Pressure (BAR)	Load (kN)	Spring Rate (kN/m)	Natural Frequency Hz
3	77.48	465	1.22
4	104.95	592	1.18
5	132.00	716	1.16
6	160.98	839	1.14
7	187.60	954	1.12

**Force Table (Use for Airstroke<sup>®</sup> actuator design)**

Assembly Height (mm)	Volume @ 7 BAR (cu cm)	EFF Area @ 7 BAR (cm sq.)	kN Force				
			@ 3 BAR	@ 4 BAR	@ 5 BAR	@ 6 BAR	@ 7 BAR
440	135784	2394	67.39	92.19	116.52	143.26	167.54
400	125615	2596	74.50	101.14	127.36	155.70	181.66
360	114722	2757	80.12	108.37	136.16	165.72	192.94
320	102796	2897	84.65	114.48	143.61	174.35	202.76
280	90465	3026	88.33	119.71	150.09	182.12	211.80
240	77839	3151	91.63	124.49	156.08	189.54	220.56
200	64589	3277	95.16	129.35	162.19	197.05	229.36
160	50778	3407	99.35	134.85	168.98	204.99	238.43