

NOTE: All Assembly Order Numbers are for bead ring parts unless noted otherwise.

	Description	Assembly Order No.
Style 323	Ribbed neck aluminum bead rings (equal spacing), 45 mm bolts, nuts, washers	W01-M58-6980
Two Ply Bellows	Rolled plate assembly, 1/2 blind nuts, 3/4 BSP	SEE NOTE BELOW
	Rubber bellows only	W01-358-7921
Assembly weight.....		14.11 kg.
Force to collapse to minimum height (@ 0 BAR) .		311 N.

Style 324	Ribbed neck aluminum bead rings (equal spacing), 45 mm bolts, nuts, washers	W01-M58-6968
High Strength Construction	Rubber bellows only	W01-358-0324

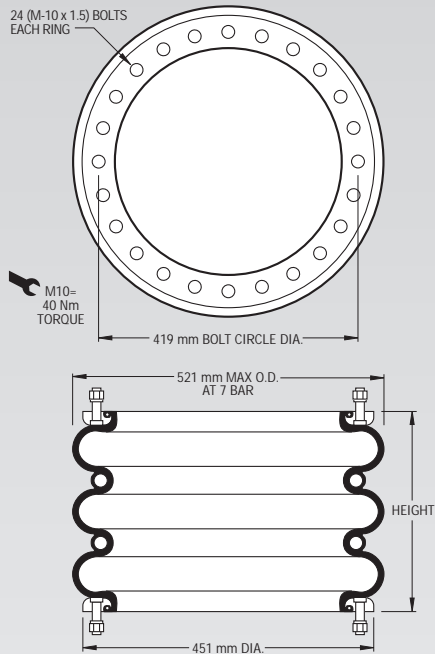

NOTE: A bead ring part is shown. This part is also available with rolled plates. See page 11 for explanation.

Gauge Pressure (BAR)	Load (kN)	Spring Rate (kN/m)	Natural Frequency Hz
3	35.44	282	1.41
4	48.94	359	1.35
5	61.63	439	1.33
6	75.25	519	1.31
7	87.73	591	1.29

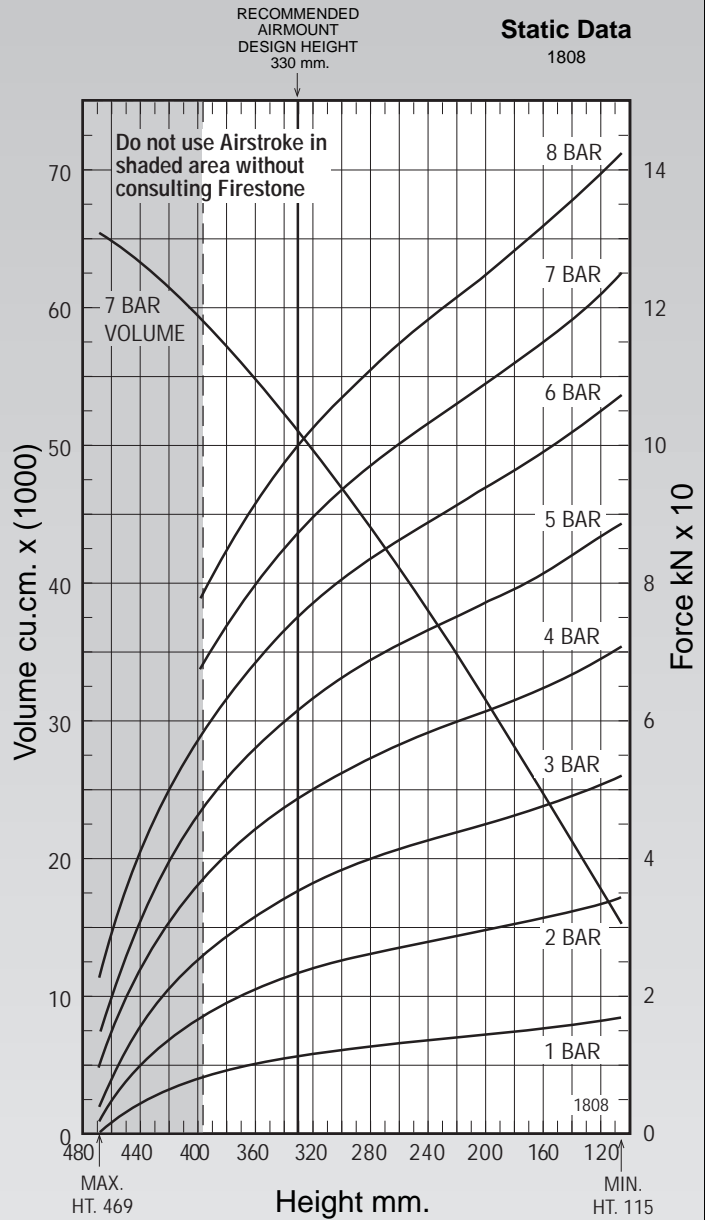

See page 12 for instructions on how to use chart.

Assembly Height (mm)	Volume @ 7 BAR (cu cm)	EFF Area @ 7 BAR (cm sq)	kN Force				
			@ 3 BAR	@ 4 BAR	@ 5 BAR	@ 6 BAR	@ 7 BAR
390	58273	1014	27.34	38.66	49.98	60.53	70.98
350	53588	1185	33.11	46.04	58.01	71.01	82.92
310	48222	1314	37.50	51.49	64.81	79.00	91.98
270	42438	1416	40.88	55.72	70.14	85.30	99.14
230	36340	1503	43.49	59.18	74.48	90.52	105.18
190	29824	1585	45.86	62.40	78.51	95.46	110.96
150	22961	1676	48.67	66.06	83.04	100.93	117.33