

5/8" BORE STAINLESS STEEL CYLINDER



USN-10-□-□

Single Acting

Mount: Universal **Standard Stroke Lengths:** 1/2", 1", 1-1/2", 2", 3", 4"
Type: Non-Rotating Rod **Spring Compressed:** 4 lbs. **Spring At Rest:** 1.3 lbs.
Options: M, B, H, V, P6, N **Maximum Stroke:** 23" For B option add 0.500
 For M option add 0.312

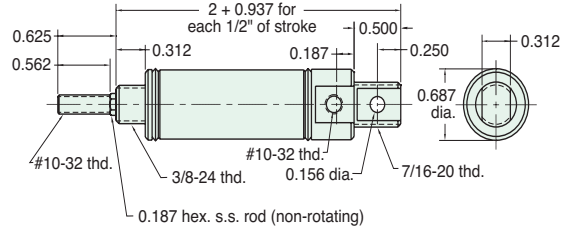

Furnished without nut(s). See Chart on Page 18.

USR-10-□-□

Single Acting

Mount: Universal **Standard Stroke Lengths:** 1/2", 1", 1-1/2", 2", 3", 4"
Type: Rotating Rod **Spring Compressed:** 4 lbs. **Spring At Rest:** 1.3 lbs.
Options: M, B, H, V, P6, N, W **Maximum Stroke:** 23" For B option add 0.500
 For M option add 0.312

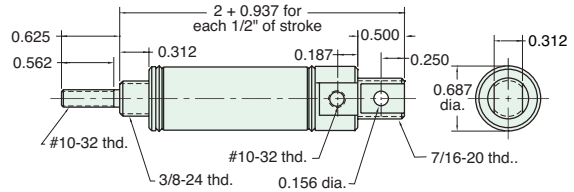

Furnished without nut(s). See Chart on Page 18.

SSN-10-□-□

Single Acting

Mount: Stud **Standard Stroke Lengths:** 1/2", 1", 1-1/2", 2", 3", 4"
Type: Non-Rotating Rod **Spring Compressed:** 4 lbs. **Spring At Rest:** 1.3 lbs.
Options: M, B, H, V, S, N **Maximum Stroke:** 23" For B option add 0.500
 For M option add 0.312

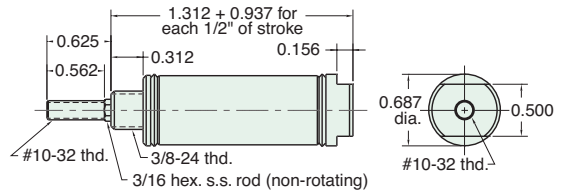

Nut included, but not shown on drawing

SSR-10-□-□

Single Acting

Mount: Stud **Standard Stroke Lengths:** 1/2", 1", 1-1/2", 2", 3", 4"
Type: Rotating Rod **Spring Compressed:** 4 lbs. **Spring At Rest:** 1.3 lbs.
Options: M, B, H, V, S, N, W **Maximum Stroke:** 23" For B option add 0.500
 For M option add 0.312

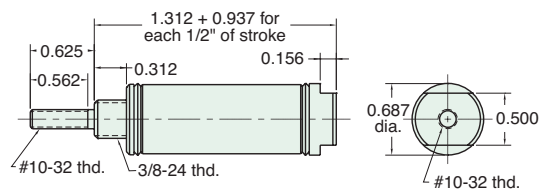

Nut included, but not shown on drawing



5/8" BORE STAINLESS STEEL CYLINDER

FSR-10-□-□

Single Acting



Mount: Front **Standard Stroke Lengths:** 1/2", 1", 1-1/2", 2", 3", 4"
Type: Rotating Rod **Spring Compressed:** 4 lbs. **Spring At Rest:** 1.3 lbs. For B option add 0.375
Options: M, B, H, V, S, N, W **Maximum Stroke:** 13" For M option add 0.312
 For S option add 0.187

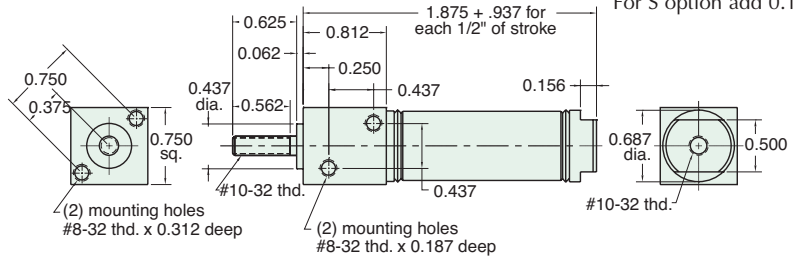

Furnished without nut(s). See Chart on Page 18.

FDR-10-□-□

Double Acting



Mount: Front **Standard Stroke Lengths:** 1/2", 1", 1-1/2", 2", 3", 4"
Type: Rotating Rod **Maximum Stroke:** 43"
Options: M, B, V, P6, P7, P8, S, N, W For B option add 0.500
 For M option add 0.312
 For S option add 0.187

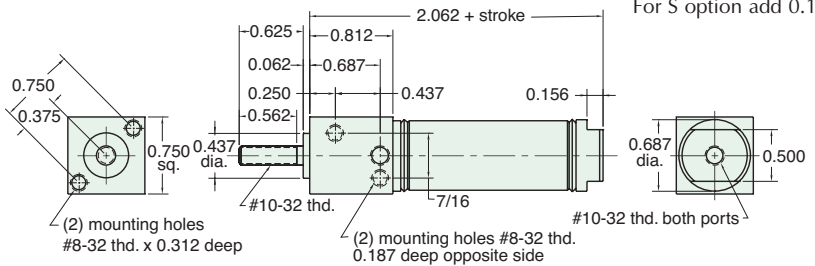

SDR-10-□-□

Double Acting



Mount: Stud **Standard Stroke Lengths:** 1/2", 1", 1-1/2", 2", 3", 4"
Type: Rotating Rod **Maximum Stroke:** 43"
Options: M, B, V, P6, P7, P8, S, N, W For B option add 0.500
 For M option add 0.312
 For S option add 0.187

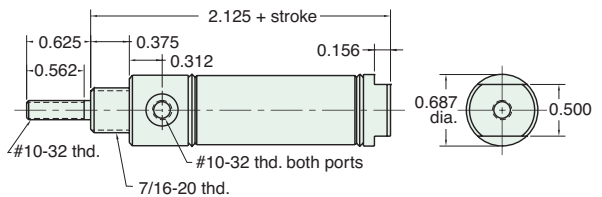

Nut included, but not shown on drawing

UDR-10-□-□

Double Acting



Mount: Universal **Standard Stroke Lengths:** 1/2", 1", 1-1/2", 2", 3", 4"
Type: Rotating Rod **Maximum Stroke:** 43"
Options: M, B, V, P2, P3, P4, P5, P6, P7, P8, N, W For B option add 0.500
 For M option add 0.312

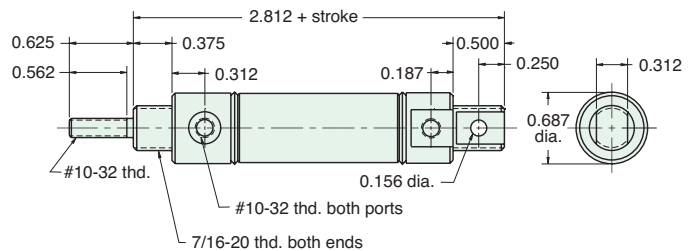

Furnished without nut(s). See Chart on Page 18.

5/8" BORE STAINLESS STEEL CYLINDER



SDD-10-□-□

Double Acting

Mount: Stud **Standard Stroke Lengths:** 1/2", 1", 1-1/2", 2", 3", 4"
Type: Double Rod **Maximum Stroke:** 20"
Options: M, B, V, P6, P7, P8, N, W For B option add 0.500
 For M option add 0.812

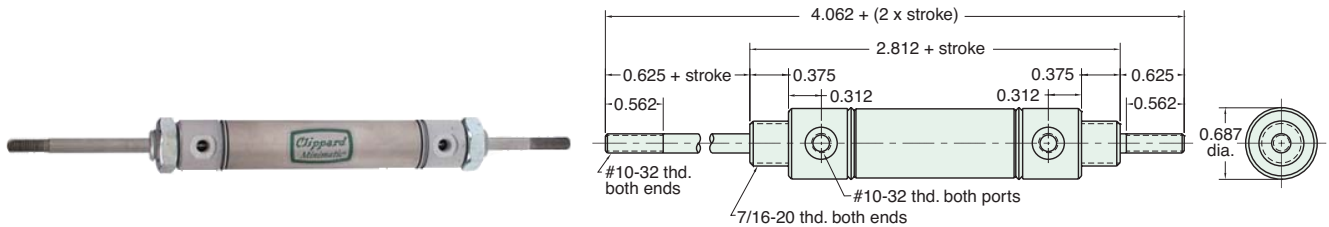

Nut included, but not shown on drawing

SRR-10-□-□

Reverse Acting

Mount: Stud **Standard Stroke Lengths:** 1/2", 1", 1-1/2", 2", 3", 4"
Type: Rotating Rod **Spring Compressed:** 4 lbs. **Spring At Rest:** 1.3 lbs.
Options: M, B, H, V, N, W **Maximum Stroke:** 15"
 For B option add 0.500
 For M option add 0.812

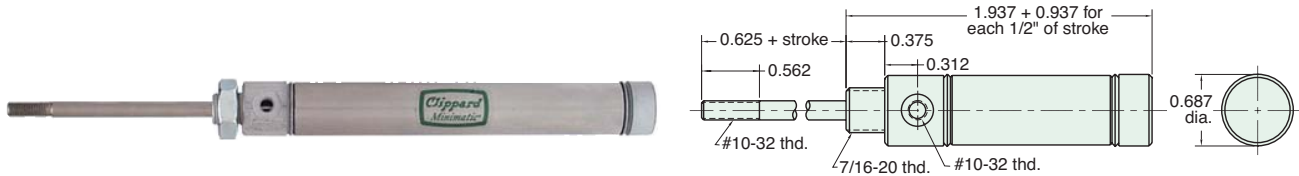

Nut included, but not shown on drawing

URR-10-□-□

Reverse Acting

Mount: Universal **Standard Stroke Lengths:** 1/2", 1", 1-1/2", 2", 3", 4"
Type: Rotating Rod **Spring Compressed:** 4 lbs. **Spring At Rest:** 1.3 lbs.
Options: M, B, H, V, P2, N, W **Maximum Stroke:** 14"
 For B option add 0.375
 For M option add 0.812

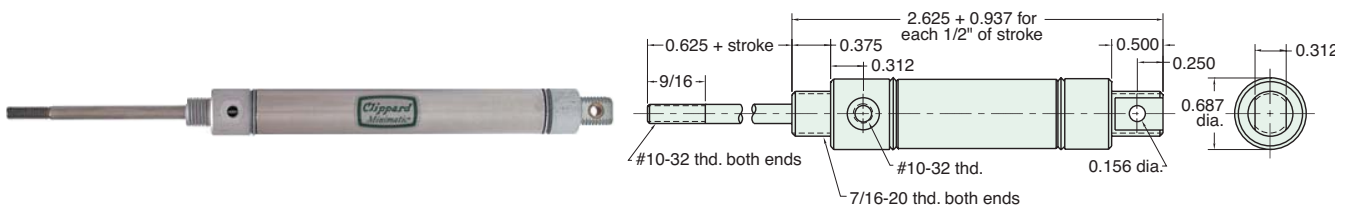

Furnished without nut(s). See Chart on Page 18.



5/8" BORE ACCESSORIES



CB-0895

Clevis Bracket
Material: Steel, bright zinc plated

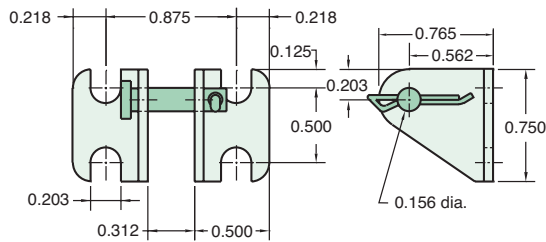

RC-0881

Rod Clevis
Material: Steel, electroless nickel plate

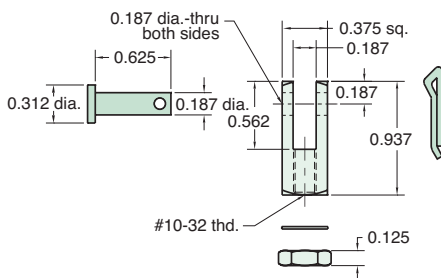

FB-0891

Foot Bracket
Material: Steel, bright zinc plated

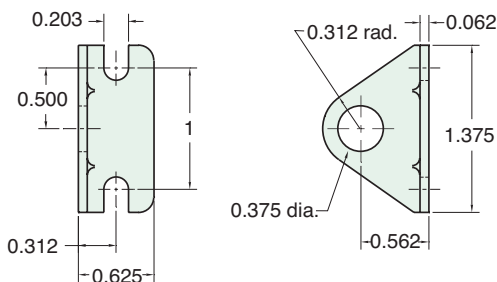

MOUNTING NUTS

Stud Nut

Part Number	Across Flats	Nut Thickness	Nut (Thread)
N06-24A	9/16"	7/32"	3/8-24
N06-24B	1/2"	1/8"	3/8-24
N07-20	11/16"	1/4"	7/16-20

Rod Nut

Part Number	Across Flats	Nut Thickness	Nut (Thread)
N03-32	3/8"	1/8"	#10-32

RE-0885

Rod End
Material: Steel, bright zinc plated body

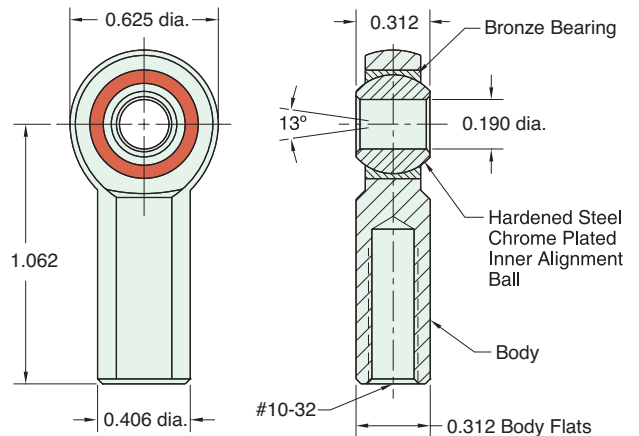

Lockwasher

Locknut

Max. Static Radial Load: 1624 lbs.
Fits Rod Thread Size: #10-32

FB-0892

Foot Bracket
Material: Steel, bright zinc plated

