

Assembly Order No.	Rubber Material	F1	F2	F3	Clamp Ring	Body Material	Max Restricted Pressure (psig/bar)	Max Unrestricted Pressure (psig/bar)
WP1-M58-0009	Neoprene	M5	M5	N/A	Stainless Steel	Steel	70 / 5	35 / 2.4
WP1-M58-0019	Silicone	M5	M5	N/A	Stainless Steel	Steel	25 / 1.8	15 / 1
WP1-358-2005	Neoprene	1/8-27 NPT	1/8-27 NPT	N/A	Stainless Steel	Steel	70 / 5	35 / 2.4
WP1-358-2013	Silicone	1/8-27 NPT	1/8-27 NPT	N/A	Stainless Steel	Steel	25 / 1.8	12 / 0.8

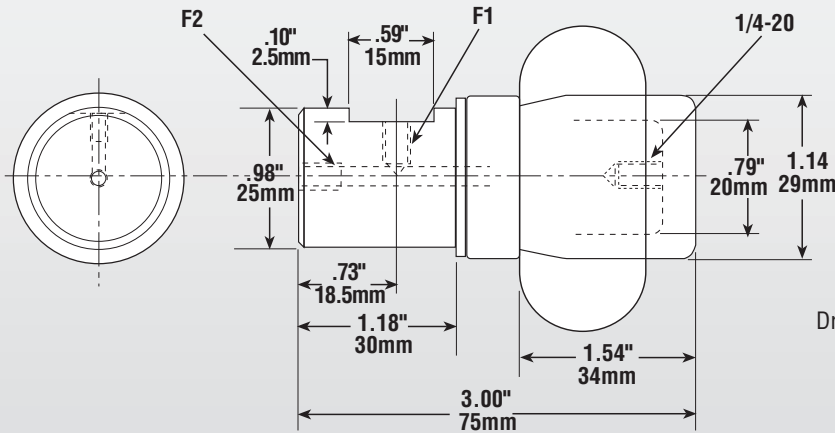

Drawing not to scale

## IMPERIAL

## METRIC

### FORCE CURVES

### FORCE CURVES

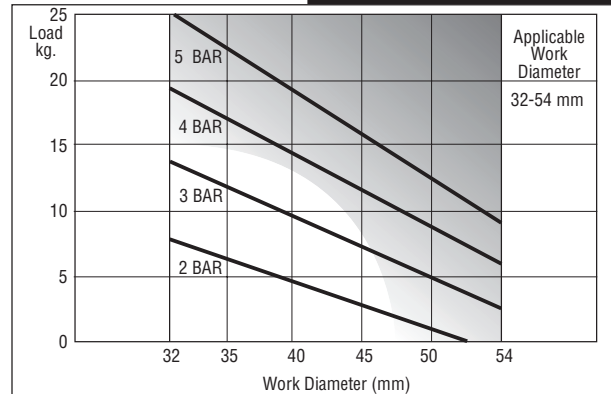
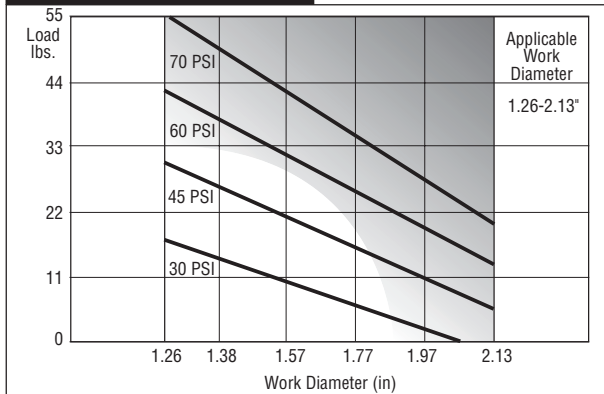

### PRESSURE VS INFLATED DIAMETER

### PRESSURE VS INFLATED DIAMETER

